

Bundle Turner for Corrugated Carton

C-BT

C-BT Bundle Turner is designed for turning the bundle for downstream strapping operation. It is an ideal machine for connecting the casemaking line to strap with carton flute.



C-BT Bundle Turner for Corrugated Carton

Main Features

- Suitable for various bundle dimensions
- Adjustable table height from 700 mm to 1000 mm
- Up and down stream interlocks with complete plug connection
- Durable frame coated with power-coating finish



Combine with TP-701CCO for squaring and strapping with the flute

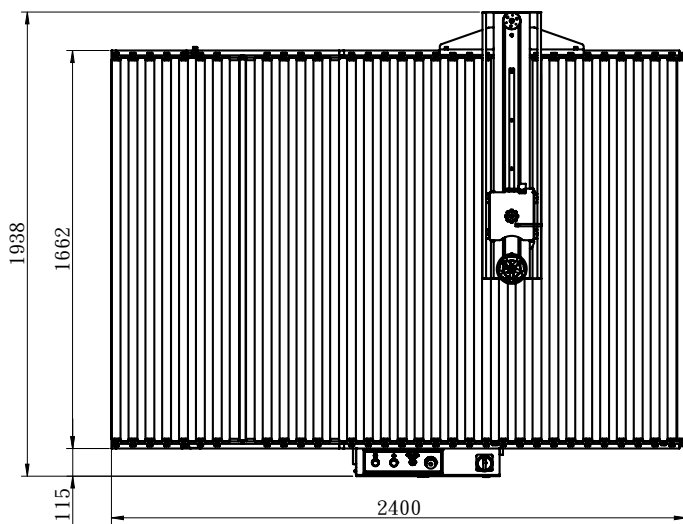

TECHNICAL DATA

Conveyor Speed: 10-55 M/minute

Table Size:

C-BT-L 1662 mm(W) X 2400 mm(D)

C-BT-M 1662 mm(W) X 1880 mm(D)

Bundle Weight: max. 35 kg

Table Height: 700 mm – 1000 mm

Electrical Requirements:

220V, 380V, 400V 50/60 Hz 3PH

Net Weight: 495 kg (C-BT-L)

477 kg (C-BT-M)

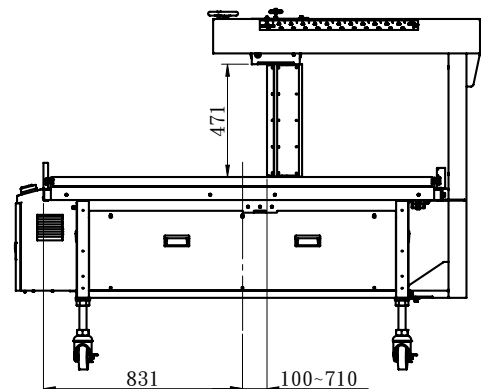
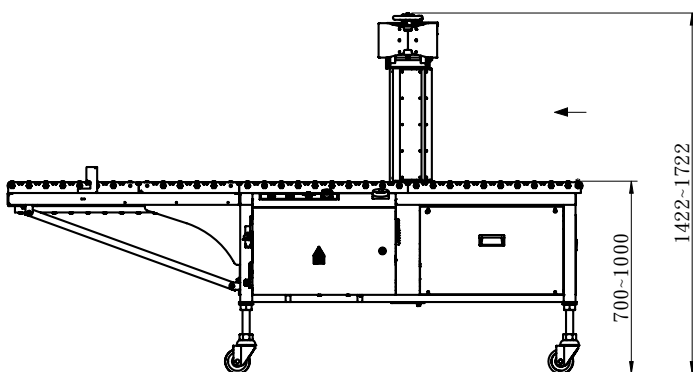

All specifications are subject to change without notice.

Full Strap srl

V. Delle Industrie, 11 Vigliano Biellese 13856 (BI) Italy

Tel. +39 015 3353310 Fax +39 015 3353313 Mail: info@fullstrap.com www.fullstrap.com