



Full Strap
Advanced Strapping Systems



SEMI-AUTO STRAPPING MACHINES



Economy Model TP-202 / TP-203 / TP-202L

Mr. Reliable

TP-202 is an affordable and compact semi-auto strapping machine. It is designed for general purposes and can meet various requirements. With tens of thousands of machines exported to the world every year, the quality of TP-202 is highly approved and that is why we call this machine Mr. Reliable. **Made in Taiwan with pride.** The best sales in the world.

TP-202/TP-201 (closed frame)

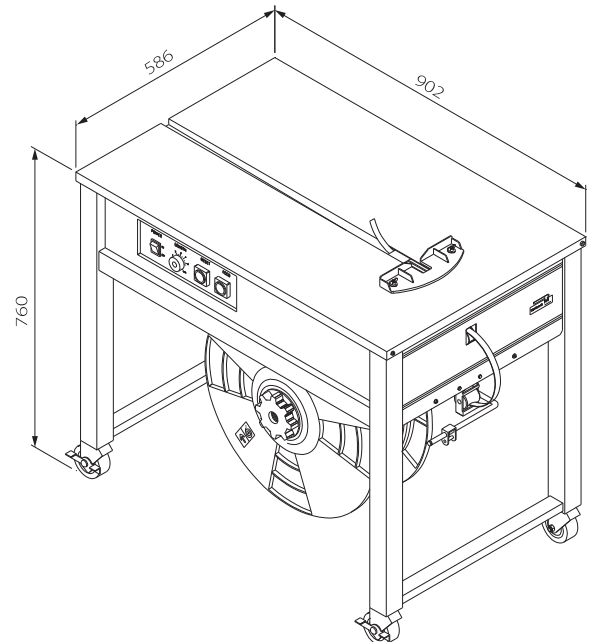

Main Features

- High engineering standard and simple design

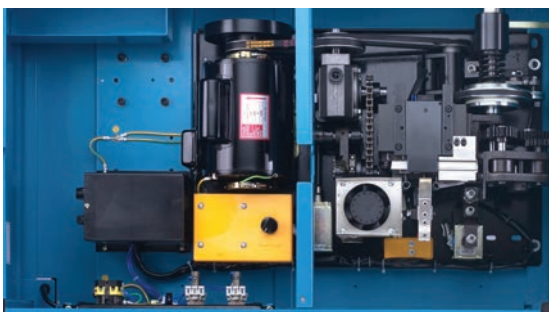

- Easy operation, simple maintenance
- Hinged stainless steel top plate
- Mechanical outside tension control
- Rigid castors with brake
- Energy efficient, motor only runs as needed
- Reliable P.C. Board control
- Affordable for every budget
- Offer maximum total value among competing brands
- Proven quality

Options

- Adjustable table height from 760 mm to 930 mm (TP-202)
- Safety switch under the table top
- Adjustable weld-cooling time (0-2 sec.)
- Stainless steel frame SUS 304 (TP-201CES)

Technical Data

Strap Width	6 mm - 15.5 mm
Tension Range	15 - 45 kg
Weight	85 kg
Electrical Requirements	110V, 220V, 230V, 240V 50/60Hz 1PH

TP-203 Mini-type model

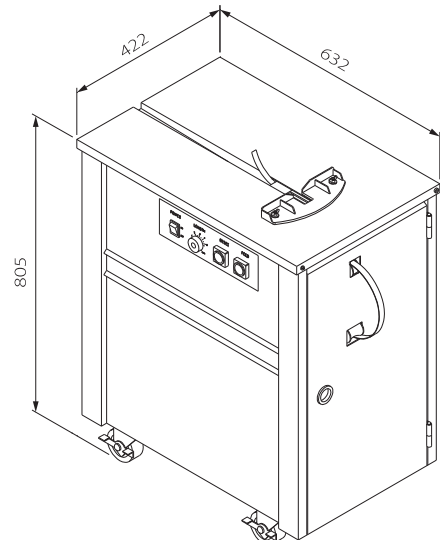

Main Features

- Designed specifically for the use in office, bank, post office, book and department store, etc.
- Equipped with **Smoke exhaust system**
- Other features are the same as TP-202

Options

- Safety switch under the table top
- Adjustable weld-cooling time (0-2 sec.)

Technical Data

Strap Width	6 mm - 15.5 mm
Tension Range	9 - 30 kg
Weight	80 kg
Electrical Requirements	110V, 220V, 230V, 240V 50/60Hz 1PH

TP-202L Low-table model

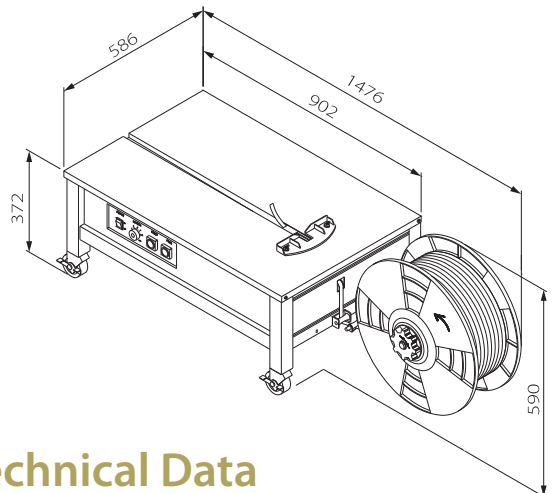

Main Features

- Designed to accommodate bulky or heavy packages
- Other features are the same as TP-202

Options

- Safety switch under the table top
- Adjustable weld-cooling time (0-2 sec.)

Technical Data

Strap Width	6 mm - 15.5 mm
Tension Range	15 - 45 kg
Weight	80 kg
Electrical Requirements	110V, 220V, 230V, 240V 50/60Hz 1PH

Genesis TP-502

New Generation Machine

TP-502 Genesis is a new generation semi-auto strapping machine. It uses direct drive technology with German-made DC motors which ensures high reliability and durability of the machine. Its compact design greatly minimizes the numbers of moving parts, requires fewer adjustments, less maintenance, and has fewer wear components.

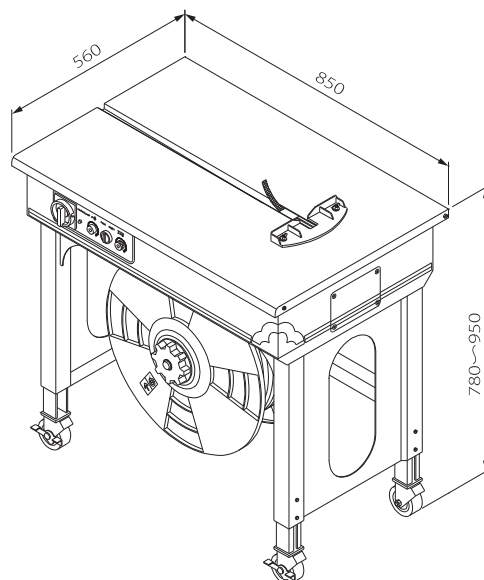

Main Features

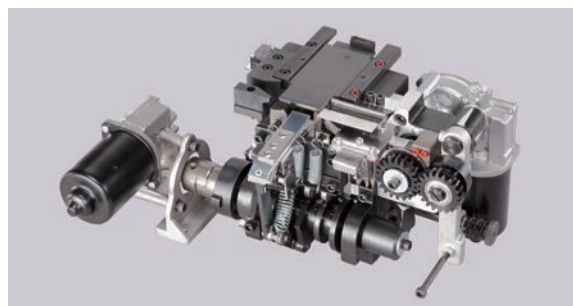

Compact Mechanical Strapping Head

With 30% less moving parts than conventional machines substantially reduces maintenance issues. There are no belts, chains, or pulleys. Extremely low noise sealing head.

Electronic Tension Control

Adjustment for strap tension (8 - 45 kg) can be easily done on the front control panel.

Jog Switch

Using the "Jog switch" to adjust the machine to exactly the correct position for maintenance.

Adjustable Weld-Cooling Time

The weld cooling time can be increased to ensure high joint efficiency under high tension.

Option

- Safety switch under the table top
- Closed frame available (TP-501)

Technical Data

Strap Width	5 mm - 12 mm or 12 mm - 15.5 mm
Tension Range	8 - 45 kg
Table Height	780 - 950 mm
Weight	70 kg
Electrical Requirements	110V, 220V, 230V, 240V 50/60Hz 1PH



FULL STRAP SRL

Via delle industrie 11 - 13856 Vigliano Biellese (BI) - Italy

Tel. +39 015 3353310 - e-mail info@fullstrap.com

www.fullstrap.com