



Full Strap
Advanced Strapping Systems



FULLY AUTOMATIC STRAPPING MACHINES



Transpak Fully Automatic Strapping Machines

Mercury Series



TP-702A

- High value-added machine with high strapping speed to meet fast production line
- **Roller-driven table** for heavy load packages
- For 5 mm, 6 mm, 9 mm, or 12 mm PP strapping
- Robust & compact strapping head, use the latest DC motor direct drive technology
- Free access to strap guides (patents registered)
- Waist-high auto strap feeding
- Waist-high quick coil change
- Capacity up to 36 packages per minute



TP-702AH

- High value-added machine with high strapping speed to meet fast production line
- **Roller-driven table** for heavy load packages
- **Siemens PLC and HMI**
- For 5 mm, 6 mm, 9 mm, or 12 mm PP strapping
- Robust & compact strapping head, use the latest DC motor direct drive technology
- Free access to strap guides (patents registered)
- Waist-high auto strap feeding
- Waist-high quick coil change
- Capacity up to 36 packages per minute



TP-702B

- High value-added machine with high strapping speed to meet fast production line
- **Belt-driven table**
- For 5 mm, 6 mm, 9 mm, or 12 mm PP strapping
- Robust & compact strapping head, use the latest DC motor direct drive technology
- Free access to strap guides (patents registered)
- Waist-high auto strap feeding
- Waist-high quick coil change
- Capacity up to 40 packages per minute

Mercury Series



TP-702BH

- High value-added machine with high strapping speed to meet fast production line
- **Belt-driven table**
- **Siemens PLC and HMI**
- For 5 mm, 6 mm, 9 mm, or 12 mm PP strapping
- Robust & compact strapping head, use the latest DC motor direct drive technology
- Free access to strap guides (patents registered)
- Waist-high auto strap feeding
- Waist-high quick coil change
- Capacity up to 40 packages per minute



TP-702BP

- High value-added machine with high strapping speed to meet fast production line
- **Belt-driven table with pneumatic press.** Ideal for strapping compressible package for better product stability and containment
- For 5 mm, 6 mm, 9 mm, or 12 mm PP strapping
- Robust & compact strapping head, use the latest DC motor direct drive technology
- Free access to strap guides (patents registered)
- Waist-high auto strap feeding
- Waist-high quick coil change
- Capacity up to 36 packages per minute



TP-702BPH

- High value-added machine with high strapping speed to meet fast production line
- **Belt-driven table with pneumatic press.** Ideal for strapping compressible package for better product stability and containment
- **Siemens PLC and HMI**
- For 5 mm, 6 mm, 9 mm, or 12 mm PP strapping
- Robust & compact strapping head, use the latest DC motor direct drive technology
- Free access to strap guides (patents registered)
- Waist-high auto strap feeding
- Waist-high quick coil change
- Capacity up to 36 packages per minute

Transpak Fully Automatic Strapping Machines

Tauris Series



TP-601A

- Robust mechanism design and high engineering standard strapping head
- **Roller-driven table**
- For 8 mm, 9 mm, or 12 mm PP strapping
- Auto strap feeding
- Electronic tension control
- Auto strap ejector
- Auto strap refeed
- Capacity up to 18 packages per minute

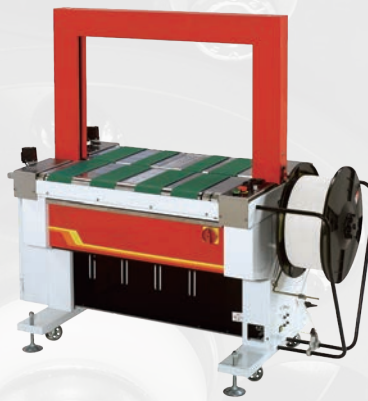

TP-601B

- Robust mechanism design and high engineering standard strapping head
- **Belt-driven table**
- For 8 mm, 9 mm, or 12 mm PP strapping
- Auto strap feeding
- Electronic tension control
- Auto strap ejector
- Auto strap refeed
- Capacity up to 18 packages per minute



TP-601BP

- Robust mechanism design and high engineering standard strapping head
- **Belt-driven table with pneumatic press**
- For 8 mm, 9 mm, or 12 mm PP strapping
- Auto strap feeding
- Electronic tension control
- Auto strap ejector
- Auto strap refeed
- Capacity up to 18 packages per minute

FULLY AUTOMATIC STRAPPING MACHINES

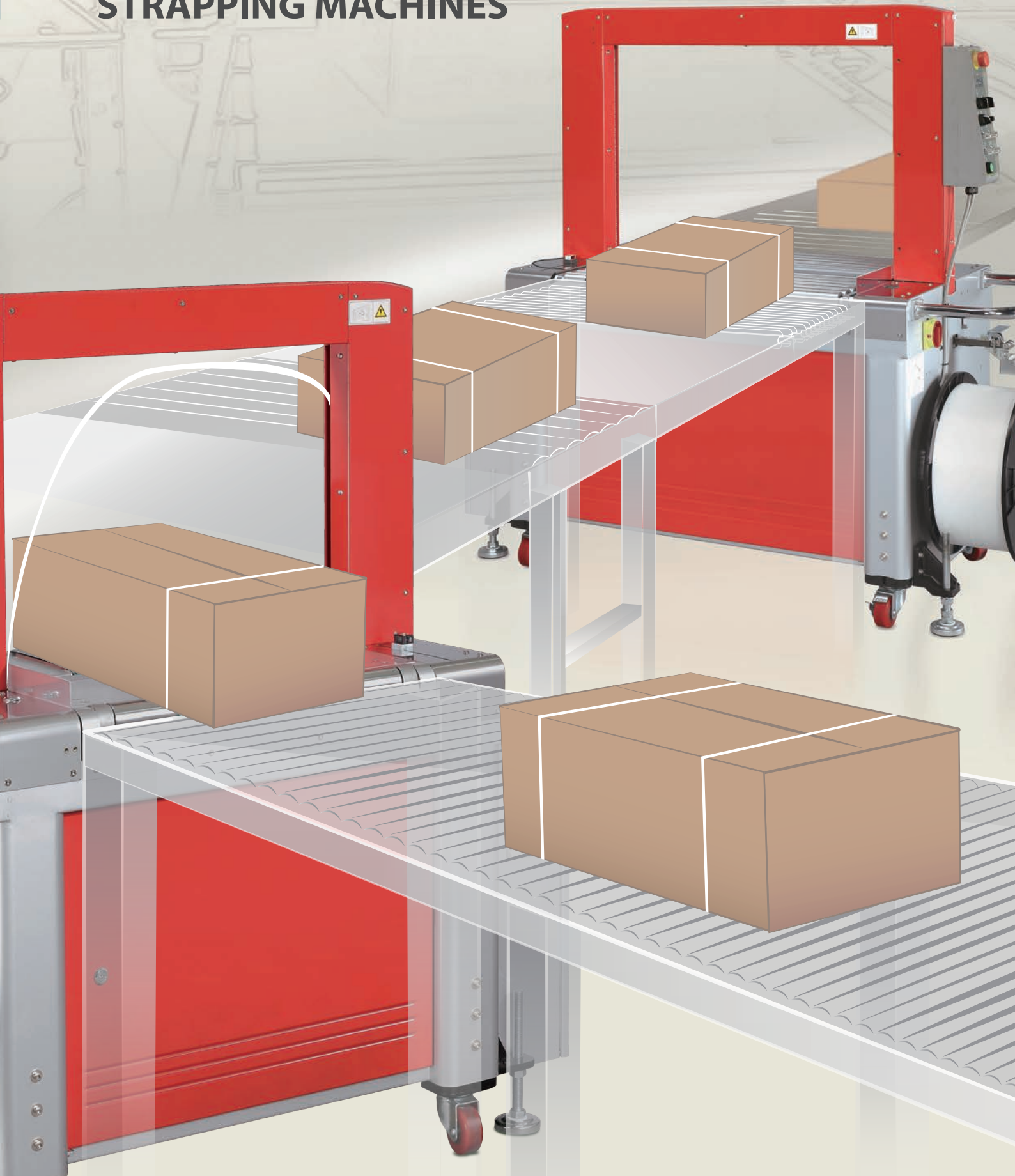

Mercury Transit

TP-702A / TP-702B / TP-702BP

High Speed Fully Automatic Strapping Machine

TP-702A, TP-702B, and TP-702BP are fully automatic strapping machines for fast production and packaging lines. It is suitable for 5 mm, 6 mm, 9 mm, or 12 mm PP strapping. TP-702A, TP-702B, and TP-702BP are the fastest and most reliable strapping machines for general applications on the market today.

TP-702A Roller-driven table

TP-702B Belt-driven table

TP-702BP Belt-driven table with pneumatic press



Main Features

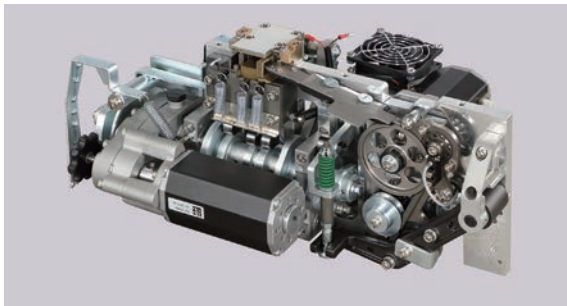

Robust and Compact Strapping Head

Use the latest brushless DC motor direct drive technology to provide the highest level of accuracy and reliability. All motors are German-made. Without belts, clutches, and pulleys, its compact design greatly minimizes the numbers of moving parts and maintenance cost.

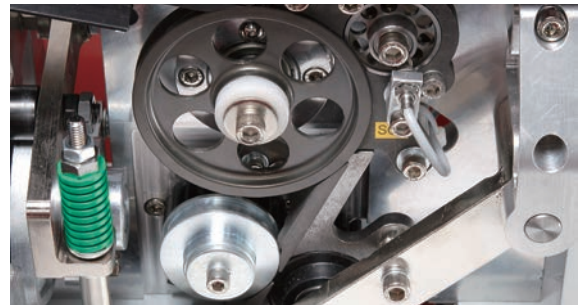

Free Access to Strap Guides (patents registered)

Hinged top plate makes easy access to the strapping head for quick maintenance. Unblocking the guides enables free and quick access to strap guides without using any tools. The most maintenance friendly design.



Waist-High Auto Strap Feeding

Friendly design to feed the strap automatically from the upper side of the coil without the need to access to the bottom of the machine.



Electronic Tension Control

The operating control panel with LCD display is located on upper side of the machine for easy access. Strap tension can be adjusted accurately by a simple turn of the dial.

More Features

Good to Strap Small Package (TP-702B/TP-702BP)

The minimum package size is 120 mm in width and 10 mm in height.

Good for Heavy Packages (TP-702A)

The robust roller-driven table can load up to 80 kg packages.

Multiple Strap Function

For single, double, continuous strapping, or transit mode.

Up and Down Stream Interlock

With complete plug connection. Easily integrated into most production lines.

Easy Bundle Flow Direction Change

The bundle flow direction could be reversed easily to meet different production line requirements.

Strap End Ejector

Eject the end of strap from the inlet of strap feeding. Easy to clean the end of strap and get the machine ready for next coil of strap.

Options

- **Siemens PLC**
- Light tower with low strap sensor
- Energy saving transit with auto sleep mode
- **Strapping in the center of the bundle**
- Strapping controlled with 2 photo eyes
- Extension belt-driven table of 200 mm on upstream or downstream sides (TP-702B, TP-702BP)
- Dual channel E-Stop
- Lower adjustable table height from 750 mm to 900 mm
- Stainless steel frame (TP-702BS, TP-702BPS)

Arch Sizes

H \ W	550	650	850	1050	1250
500	✓	Ⓢ2			
600			✓ Ⓢ1		✓
800			✓ ✓	✓ ✓	
1000			✓		

TP-702A:

Ⓢ1 Standard size : 850 mm (W) x 600 mm (H)

✓ means available arch size

TP-702B / TP-702BP:

Ⓢ2 Standard size: 650 mm (W) x 500 mm (H)

✓ means available arch size

- Arch size 850 mm (W) x 1000 mm (H) is only available on TP-702B

TP-702A

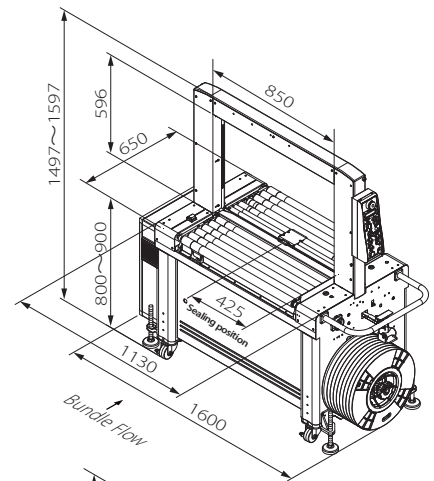

TP-702B

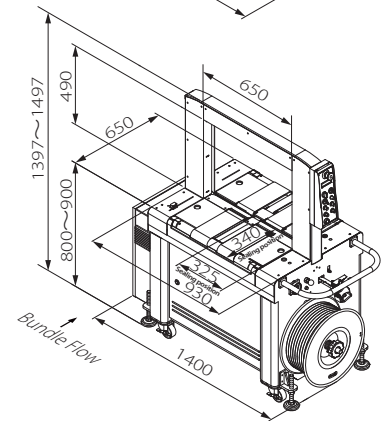

TP-702BP

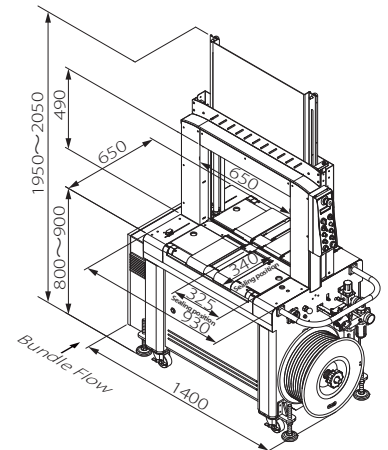

Technical Data

Capacity	Up to 40 packages/minute (TP-702B) Up to 36 packages/minute (TP-702A, TP-702BP)
Strap Width	5 mm, 6 mm, 9 mm, or 12 mm
Tension Range	1 - 32 kg (for 5 mm, 6 mm, 9 mm) 1 - 45 kg (for 12 mm) *Higher tension is on request
Pneumatic Source & Air Consumption	6 bar 7.5 liter/cycle (TP-702BP)
Weight	287 kg (TP-702A), 225 kg (TP-702B) 250 kg (TP-702BP)
Electrical Requirements	110V, 220V, 230V, 240V 50/60Hz 1PH 220V, 380V, 400V, 415V 50/60Hz 3PH

Mercury Transit

TP-702AH / TP-702BH / TP-702BPH

High Speed Fully Automatic Strapping Machine with Siemens PLC and HMI

TP-702AH, TP-702BH, and TP-702BPH are fully automatic strapping machines designed based on our best seller TP-702 Mercury with proven quality. Equipped with Siemens PLC and HMI as standard, they are born with higher flexibility and better adaptability in a wider range of applications. Thanks to their high speed design with reliable performance, they are highly recommended for high capacity production lines.

TP-702AH Roller-driven table

TP-702BH Belt-driven table

TP-702BPH Belt-driven table with pneumatic press



Main Features

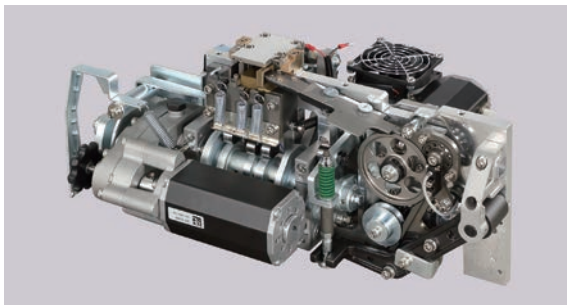

Robust and Compact Strapping Head

Use the latest brushless DC motor direct drive technology to provide the highest level of accuracy and reliability. All motors are German-made. Without belts, clutches, and pulleys, its compact design greatly minimizes the numbers of moving parts and maintenance cost.

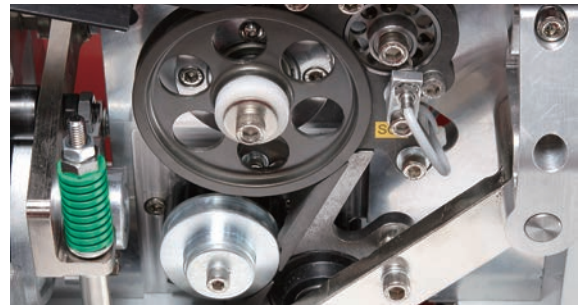

Free Access to Strap Guides (patents registered)

Hinged top plate makes easy access to the strapping head for quick maintenance. Unblocking the guides enables free and quick access to strap guides without using any tools. The most maintenance friendly design.



Waist-High Auto Strap Feeding

Friendly design to feed the strap automatically from the upper side of the coil without the need to access to the bottom of the machine.



Siemens PLC and HMI

Provide easy adjustments, operation instructions, troubleshooting guides and real-time sensor status display.

More Features

Good to Strap Small Package (TP-702BH / TP-702BPH)

The minimum package size is 120 mm in width and 10 mm in height.

Good for Heavy Packages (TP-702AH)

The robust roller-driven table can load up to 80 kg packages.

Diverse Strapping Patterns

The setting for different strapping patterns can be done via visual display on HMI very easily.

Up and Down Stream Interlock

With complete plug connection. Easily integrated into most production lines.

Easy Bundle Flow Direction Change

The bundle flow direction could be reversed easily to meet different production line requirements.

Options

- Light tower with low strap sensor
- Energy saving transit with auto sleep mode
- **Strapping in the center of the bundle**
- Strapping controlled with 2 photo eyes
- **Automatic tension control by package height detection** (3 stage tension)
- **Automatically determining the number of straps by package length**
- Extension belt-driven table of 200 mm on upstream or downstream sides (TP-702BH, TP-702BPH)
- Dual channel E-Stop
- **Signal exchange via 16 pin connector**
- Lower adjustable table height from 750 mm to 900 mm
- Stainless steel frame (TP-702BHS, TP-702BPHS)

Arch Sizes

H \ W	550	650	850	1050	1250
500	✓	Ⓢ2			
600			✓ Ⓢ1		✓
800			✓ ✓	✓ ✓	
1000			✓		

TP-702AH:

Ⓢ1 Standard size : 850 mm (W) x 600 mm (H)

✓ means available arch size

TP-702BH / TP-702BPH:

Ⓢ2 Standard size: 650 mm (W) x 500 mm (H)

✓ means available arch size

- Arch size 850 mm (W) x 1000 mm (H) is only available on TP-702BH

TP-702AH

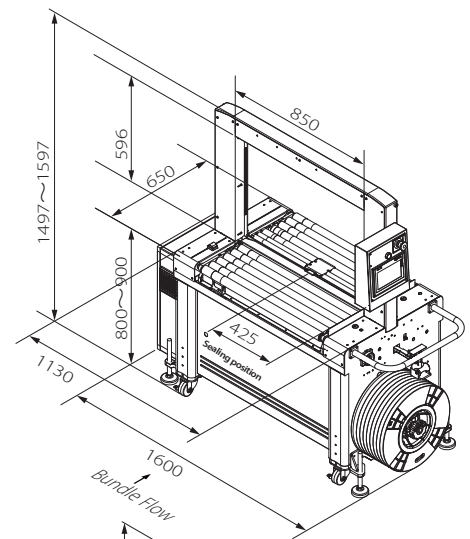

TP-702BH

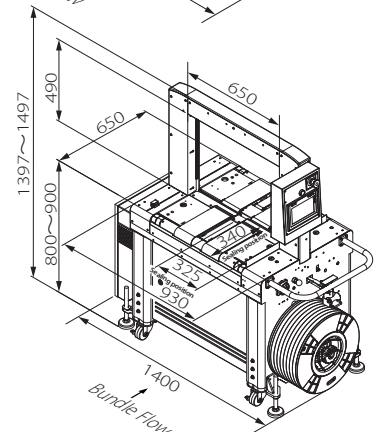

TP-702BPH

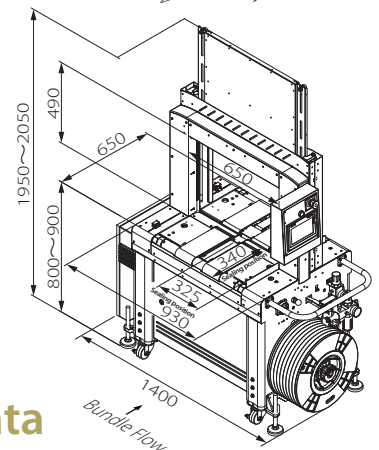

Technical Data

Capacity	Up to 40 packages/minute (TP-702BH) Up to 36 packages/minute (TP-702AH, TP-702BPH)
Strap Width	5 mm, 6 mm, 9 mm, or 12 mm
Tension Range	1 - 32 kg (for 5 mm, 6 mm, 9 mm) 1 - 45 kg (for 12 mm) *Higher tension is on request
Pneumatic Source & Air Consumption	6 bar 7.5 liter/cycle (TP-702BPH)
Weight	290 kg (TP-702AH) 228 kg (TP-702BH) 253 kg (TP-702BPH)
Electrical Requirements	110V, 220V, 230V, 240V 50/60Hz 1PH 220V, 380V, 400V, 415V 50/60Hz 3PH

Tauris Transit

TP-601A / TP-601B / TP-601BP

Fully Automatic Strapping Machine

TP-601A, TP-601B, and TP-601BP are fully automatic strapping machines built with Transpak Tauris TP-601D strapping head. These machines deliver high reliability and excellent performance. Tauris Transit machines are simple and the most reliable fully automatic strapping machines for general purpose applications on the market today.

TP-601A Roller-driven table

TP-601B Belt-driven table

TP-601BP Belt-driven table with pneumatic press



Main Features

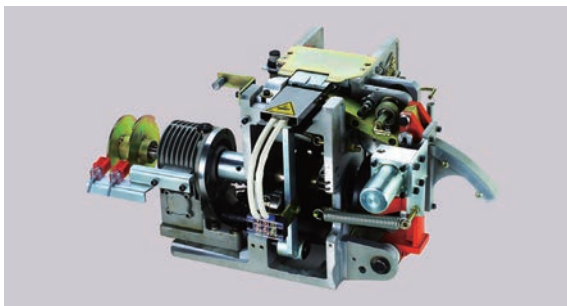

Reliable and Robust Strapping Head

Robust mechanism design and high engineering standard ensure excellent durability of the machine. Use two proximity switches to replace conventional limit switches. Maintenance friendly lubrication free design.

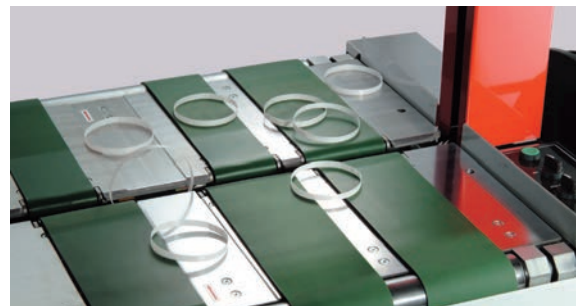

Auto Strap Ejector

Loop-ejector clears unwanted strap automatically if the machine is accidentally activated without a package. Eliminates downtime.



Electronic Tension Control

Strap tension can be adjusted accurately by a simple turn of the dial. Easy operation.



Auto Strap Feeding (patents registered)

Friendly design to feed the strap automatically from the inlet of strap feeding without the need to access to the inside of the machine. Easy strap loading.

More Features

Multiple Strap Function

For single, double, continuous strapping, or transit mode.

Up and Down Stream Interlock

With complete plug connection. Easily integrated into most production lines.

Easy Bundle Flow Direction Change

The bundle flow direction could be reversed easily to meet different production line requirements.

Belt Transmission

Instead of using roller chain, belt transmission system ensures long operational life and quiet operation.

Short Feed Sensor

The sensor detects whether the strap is at sealing position. If not, the strapping cycle cannot be activated.

Auto Strap Refeed

The machine will automatically refeed the strap if a mis-feed occurs.

Strap End Ejector

Eject the end of strap automatically. Easy to clean the end of strap and get the machine ready for next coil of strap.

Hinged Top Plates

Easy and effortless to open the table top for cleaning and maintenance. Ergonomic design.

Options

- **Siemens PLC**
- Variable conveyor speed from 18 to 42 meters per minute
- Smoke exhaust system with carbon filter
- Foot pedal switch
- PU casters (2 free and 2 with brake)
- Safety guards

Arch Sizes

H \ W	850	1050	1250
400	✓	✓	✓
600	Ⓢ	✓	✓
800	✓	✓	✓
1000	✓	✓	✓
1200		✓	

Ⓢ Standard size: 850 mm (W) x 600 mm (H)

✓ means available arch size

- Arch size 1050 mm (W) x 1200 mm (H) is only available on TP-601A / TP-601B

TP-601A

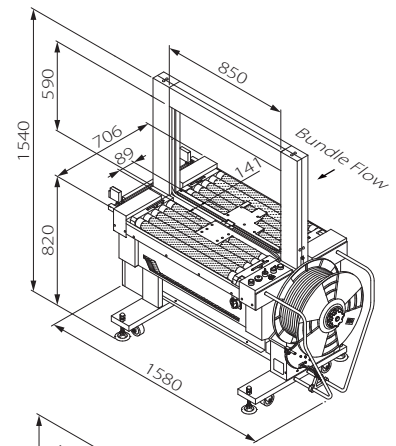

TP-601B

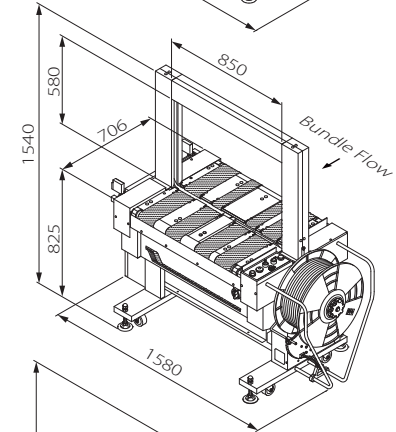

TP-601BP

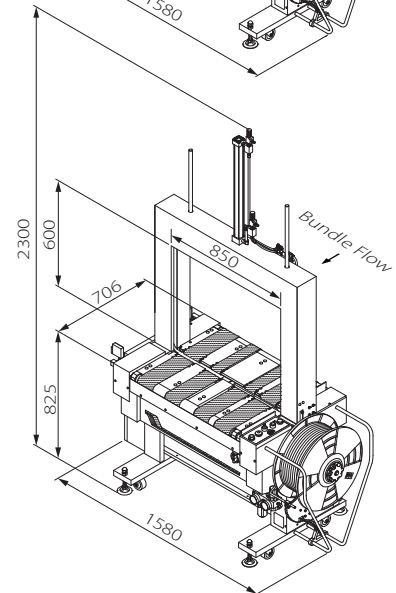

Technical Data

Capacity	Up to 18 packages/minute
Strap Width	8 mm, 9 mm, or 12 mm
Tension Range	7 - 45 kg *up to 70 kg on request
Conveyor Speed	30 meters/minute
Pneumatic Source & Air Consumption	6 bar 10 liter/cycle (TP-601BP)
Weight	335 kg (TP-601A) 325 kg (TP-601B) 347 kg (TP-601BP)
Electrical Requirements	220V, 380V, 400V, 415V 50/60Hz 3PH

ALWAYS MORE THAN YOU EXPECT

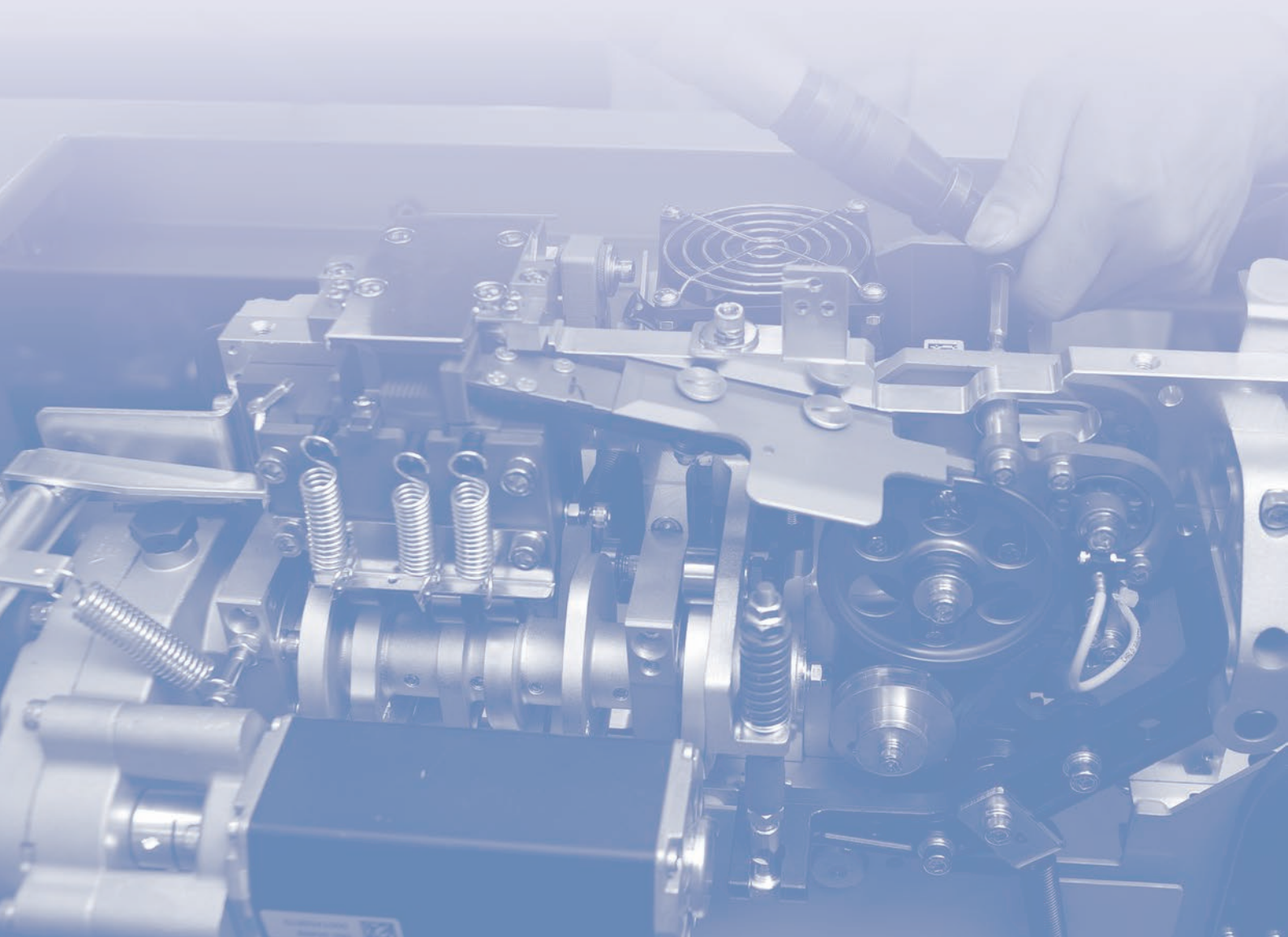

FULL STRAP SRL

Via delle industrie 11 - 13856 Vigliano Biellese (BI) - Italy

Tel. +39 015 3353310 - e-mail info@fullstrap.com

www.fullstrap.com