



**Full Strap**  
Advanced Strapping Systems



# PRINT MEDIA INDUSTRY STRAPPING SOLUTIONS



# Transpak Print Media Industry Strapping Solutions

## Fully Automatic Strapping Machine



### TP-702NS

- High speed strapping machine for single and parallel strapping
- With Siemens PLC control, easy integration to production lines
- For 5 mm, 6 mm, or 9 mm PP strapping
- Robust and compact mechanical strapping head
- Latest German-made brushless DC motor direct drive technology
- Automatic tension control for various bundle dimensions (patents registered)
- Free access to strap guides (patents registered)
- Easy access to strapping head (patents registered)
- Preprogram setting for multiple strapping patterns
- Capacity up to 42 bundles per minute

## Fully Automatic Longitudinal Strapping Machine



### TP-702NL

- Strapping applied in transport direction
- Automatic self-adjusting strap chute (patents registered)
- With Siemens PLC control, easy integration to production lines
- For 5 mm, 6 mm, or 9 mm PP strapping
- Robust and compact mechanical strapping head
- Latest German-made brushless DC motor direct drive technology
- Automatic tension control for various bundle dimensions (patents registered)
- Free access to strap guides (patents registered)
- Easy access to strapping head (patents registered)
- Preprogram setting for multiple strapping patterns
- Capacity up to 31 bundles per minute



## Inline Cross Strapping System



### TP-702NIL

- Inline cross strapping system without bundle turning
- The system consists of TP-702NS and TP-702NL strapping machines
- With Siemens PLC control, easy integration to production lines
- For 5 mm, 6 mm, or 9 mm PP strapping
- Robust and compact strapping head with latest German-made brushless DC motor direct drive technology
- Automatic tension control for various bundle dimensions (patents registered)
- Automatic self-adjusting strap chute (patents registered)
- Free access to strap guides (patents registered)
- Easy access to strapping head (patents registered)
- Preprogram setting for multiple strapping patterns
- Capacity up to 31 bundles per minute

## Cross Strapping System with Angle Diverter



### TP-702NAD

- Cross strapping system
- The system consists of 2 sets TP-702NS strapping machines and N1-AD angle diverter
- With Siemens PLC control, easy integration to production lines
- For 5 mm, 6 mm, or 9 mm PP strapping
- Robust and compact strapping head with latest German-made brushless DC motor direct drive technology
- Automatic tension control for various bundle dimensions (patents registered)
- Free access to strap guides (patents registered)
- Easy access to strapping head (patents registered)
- Preprogram setting for multiple strapping patterns
- Capacity up to 25 bundles per minute

# Mercury TP-702NS

## Fully Automatic Strapping Machine

TP-702NS is a fully automatic strapping machine designed specifically for the print media industry. With its high strapping speed, it can be integrated into most production lines and utilized for various applications.



## Main Features

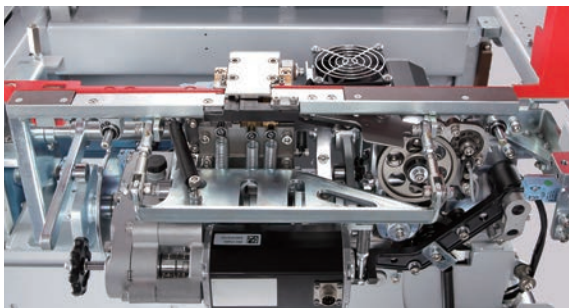

### Robust and Compact Strapping Head

Use the latest brushless DC motor direct drive technology to provide the highest level of accuracy and reliability. All motors are German-made. With compact design and fewer moving parts, it can greatly minimize the maintenance cost.

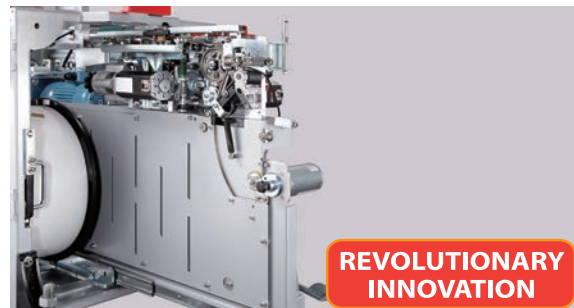

### Easy Access to Strapping Head (patents registered)

The strapping head can be pulled out without moving the machine from production line. With this most user friendly design, operators can perform maintenance on-site directly to minimize downtime.

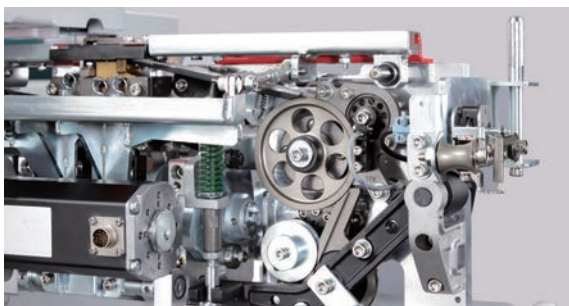

### Free Access to Strap Guides (patents registered)

Unlocking the guides enables free and quick access to strap guides without using any tools. The most maintenance friendly design.



### Siemens PLC Control and HMI

Provide easy adjustments, TEACH-IN programming, and troubleshooting guides.

## More Features

### Automatic Tension Control (patents registered)

The machine will automatically apply the most appropriate tension force to various bundle dimensions.

### Dual Pneumatic Press

Offer better bundle stability and containment.

### Up and Down Stream Interlock

With complete plug connection. Easily integrated into most production lines.

### Variable Conveyor Speed

Fully automatic operation with variable conveyor speed between 10 and 60 meters/minute.

### Strap End Ejector

Eject the end of strap from the inlet of strap feeding. Easy to clean the end of strap and get the machine ready for next coil of strap.

### Auto Strap Ejector

Loop-ejector clears unwanted strap automatically if the machine is accidentally activated without a package.

### Dispenser Release Switch

Friendly design makes it easier to pull the strap from the strap dispenser for waist-high auto strap feeding.

### Adjustable Table Height

The table height is adjustable to any height between 800 mm and 900 mm.

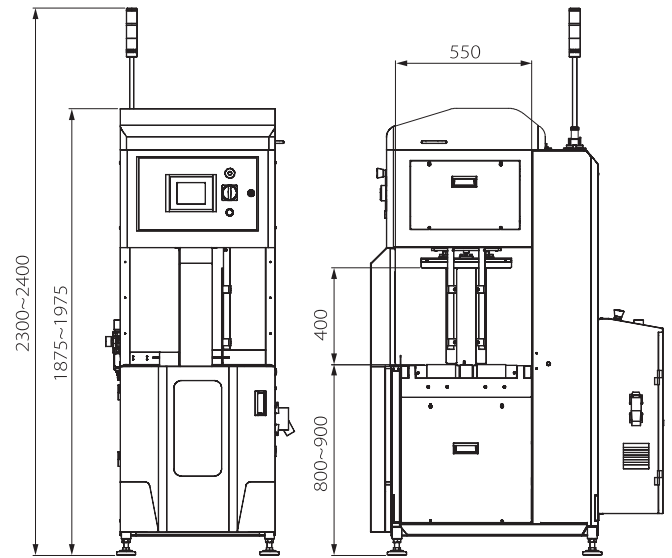
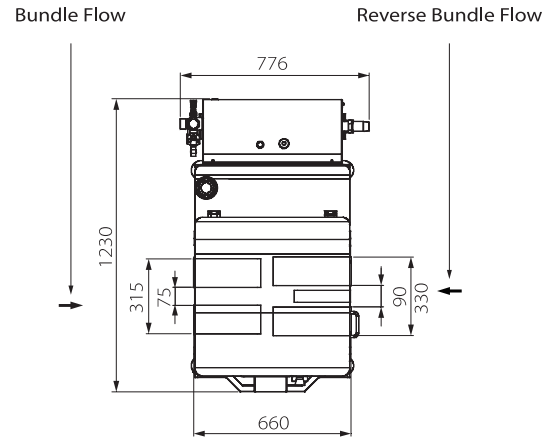

TP-702NS

## Options

- **Energy saving transit with auto sleep mode**
- **Light tower with low strap sensor** (triple lamp)
- Additional soft press for convex bundle
- Lower adjustable table height with movable casters (730 mm – 830 mm)
- **Automatic side squaring**
- Reverse bundle flow
- Low volume bundle bypass
- Movable casters (picture shown with this option)
- Lever switch for bundle with wrapping
- Extension belt-driven table of 200 mm on upstream or downstream sides

## Technical Data

<b>Capacity</b>	Up to 42 bundles/minute (single strap) Up to 24 bundles/minute (double straps)
<b>Strap Width</b>	5 mm, 6 mm, or 9 mm
<b>Tension Range</b>	1 - 32 kg
<b>Bundle Size</b>	<b>Width</b> max 500 mm min 120 mm <b>Height</b> max 390 mm min 10 mm
<b>Bundle Weight</b>	max 25 kg
<b>Pneumatic Source &amp; Air Consumption</b>	6 bar 2.65 liter/cycle
<b>Weight</b>	430 kg
<b>Electrical Requirements</b>	220V, 380V, 400V, 415V 50/60Hz 3PH

# Mercury TP-702NL

## Fully Automatic Longitudinal Strapping Machine

TP-702NL is a fully automatic longitudinal strapping machine designed specifically for the print media industry. The bundle is strapped in the transport direction.



## Main Features

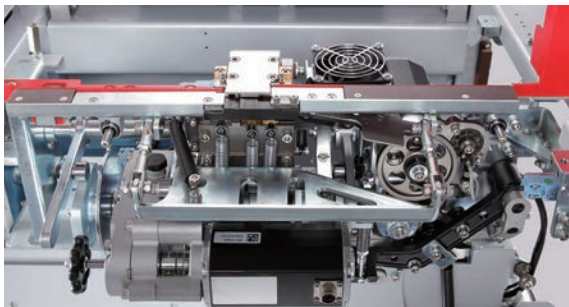

### Robust and Compact Strapping Head

Use the latest brushless DC motor direct drive technology to provide the highest level of accuracy and reliability. All motors are German-made. With compact design and fewer moving parts, it can greatly minimize the maintenance cost.

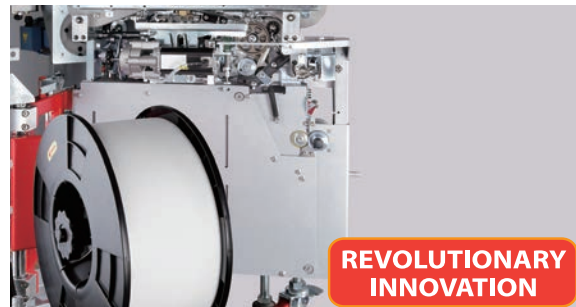

**REVOLUTIONARY  
INNOVATION**

### Easy Access to Strapping Head (patents registered)

The strapping head can be pulled out without moving the machine from production line. With this most user friendly design, operators can perform maintenance on-site directly to minimize downtime.



### Siemens PLC Control and HMI

Provide easy adjustments, TEACH-IN programming, and troubleshooting guides.



### Automatic Self-adjusting Strap Chute (patents registered)

The strap chute can detect the incoming bundle height and stop at the accurate position. This intelligent design can streamline your strapping line and increase the strapping cycle speed.

## More Features

### Free Access to Strap Guides (patents registered)

Unblocking the guides enables free and quick access to strap guides without using any tools. The most maintenance friendly design.

### Automatic Tension Control (patents registered)

The machine will automatically apply the most appropriate tension force to various bundle dimensions.

### Up and Down Stream Interlock

With complete plug connection. Easily integrated into most production lines.

### Variable Conveyor Speed

Fully automatic operation with variable conveyor speed between 10 and 60 meters/minute.

### Strap End Ejector

Eject the end of strap from the inlet of strap feeding. Easy to clean the end of strap and get the machine ready for next coil of strap.

### Auto Strap Ejector

Loop-ejector clears unwanted strap automatically if the machine is accidentally activated without a package.

### Dispenser Release Switch

Friendly design makes it easier to pull the strap from the strap dispenser for waist-high auto strap feeding.

### Adjustable Table Height

The table height is adjustable to any height between 800 mm and 900 mm.

## Options

- **Energy saving transit with auto sleep mode**
- **Light tower with low strap sensor** (triple lamp)
- Lower adjustable table height with movable casters (730 mm - 830 mm)
- Reverse bundle flow
- Low volume bundle bypass
- Movable casters (picture shown with this option)
- Adjustable side guides
- Lever switch for bundle with wrapping

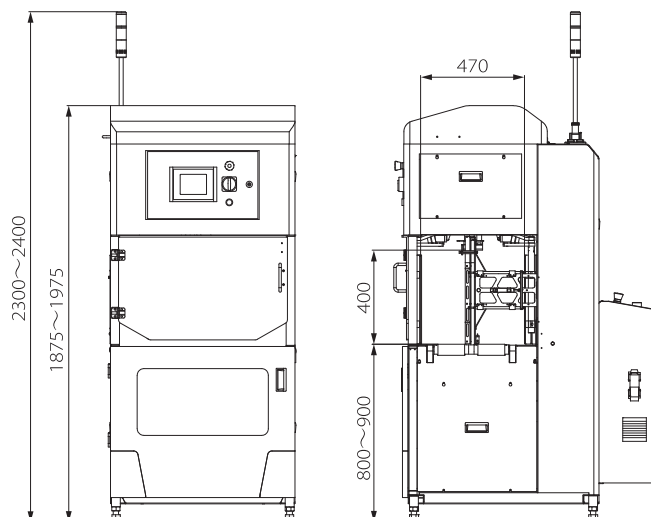
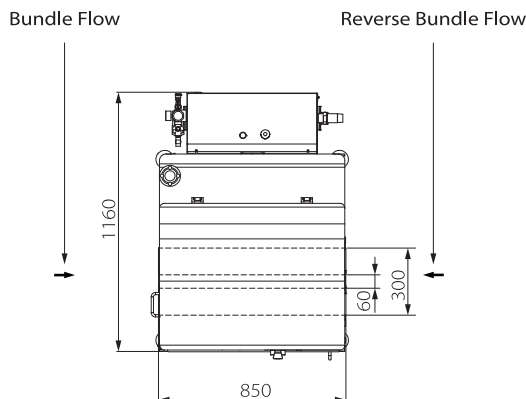

TP-702NL

## Technical Data

<b>Capacity</b>	Up to 31 bundles/minute									
<b>Strap Width</b>	5 mm, 6 mm, or 9 mm									
<b>Tension Range</b>	1 - 32 kg									
<b>Bundle Size</b>	<table border="0"> <tr> <td><b>Width</b></td> <td>max 450 mm</td> <td>min 120 mm</td> </tr> <tr> <td><b>Length</b></td> <td>max 500 mm</td> <td>min 210 mm</td> </tr> <tr> <td><b>Height</b></td> <td>max 400 mm</td> <td>min 10 mm</td> </tr> </table>	<b>Width</b>	max 450 mm	min 120 mm	<b>Length</b>	max 500 mm	min 210 mm	<b>Height</b>	max 400 mm	min 10 mm
<b>Width</b>	max 450 mm	min 120 mm								
<b>Length</b>	max 500 mm	min 210 mm								
<b>Height</b>	max 400 mm	min 10 mm								
<b>Bundle Weight</b>	max 25 kg									
<b>Pneumatic Source &amp; Air Consumption</b>	6 bar 8.53 liter/cycle									
<b>Weight</b>	475 kg									
<b>Electrical Requirements</b>	220V, 380V, 400V, 415V 50/60Hz 3PH									

# Mercury TP-702NIL

## Inline Cross Strapping System

TP-702NIL is a fully automatic strapping system for inline cross strapping. The design without bundle turning can secure the integrity of bundles for cross strapping.



## Main Features

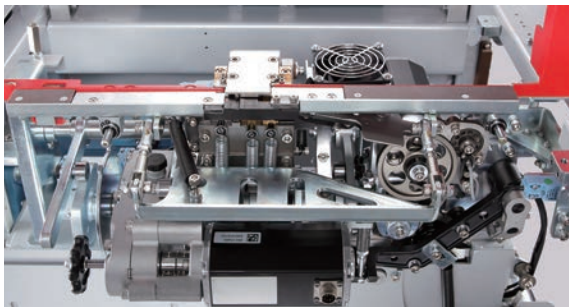

### Robust and Compact Strapping Head

Use the latest brushless DC motor direct drive technology to provide the highest level of accuracy and reliability. All motors are German-made. With compact design and fewer moving parts, it can greatly minimize the maintenance cost.

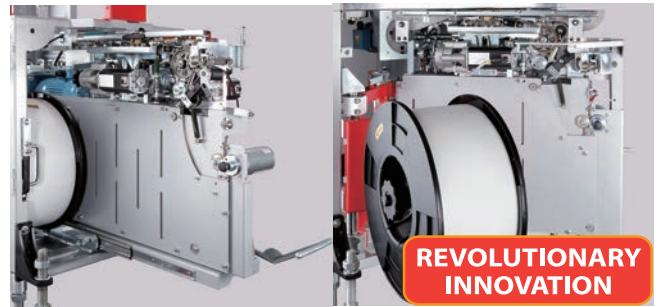

### Easy Access to Strapping Head (patents registered)

The strapping heads can be pulled out without moving the machine from production line. With this most user friendly design, operators can perform maintenance on-site directly to minimize downtime.



### Automatic Self-adjusting Strap Chute (patents registered)

The strap chute can detect the incoming bundle height and stop at the accurate position. This intelligent design can streamline your strapping line and increase the strapping cycle speed.



### Siemens PLC Control and HMI

Provide easy adjustments, TEACH-IN programming, and troubleshooting guides.



## More Features

### Cross Strapping without Turning the Bundle

With one machine strapping in transport direction, the cross strapping can be perfectly applied without turning the bundle to best secure the bundle integrity.

### Free Access to Strap Guides (patents registered)

Unblocking the guides enables free and quick access to strap guides without using any tools. The most maintenance friendly design.

### Automatic Tension Control (patents registered)

The machine will automatically apply the most appropriate tension force to various bundle dimensions.

### Auto Strap Ejector

Loop-eject clears unwanted strap automatically if the machine is accidentally activated without a package.

### Strap End Ejector

Eject end of strap from the inlet of strap feeding. Easy to clean the end of strap and get the machine ready for next coil of strap.

### Up and Down Stream Interlock

With complete plug connection. Easily integrated into most production lines.

### Variable Conveyor Speed

Fully automatic operation with variable conveyor speed between 10 and 60 meters/minute.

### Dispenser Release Switch

Friendly design makes it easier to pull the strap from the strap dispenser for waist-high auto strap feeding.

### Adjustable Table Height

The table height is adjustable to any height between 800 mm and 900 mm.

## Options

- **Energy saving transit with auto sleep mode**
- **Light tower with low strap sensor** (triple lamp)
- Additional soft press for convex bundle
- Lower adjustable table height with movable casters (730 mm – 830 mm)
- **Automatic side squaring**
- Reverse bundle flow
- Low volume bundle bypass
- Movable casters (picture shown with this option)
- Lever switch for bundle with wrapping

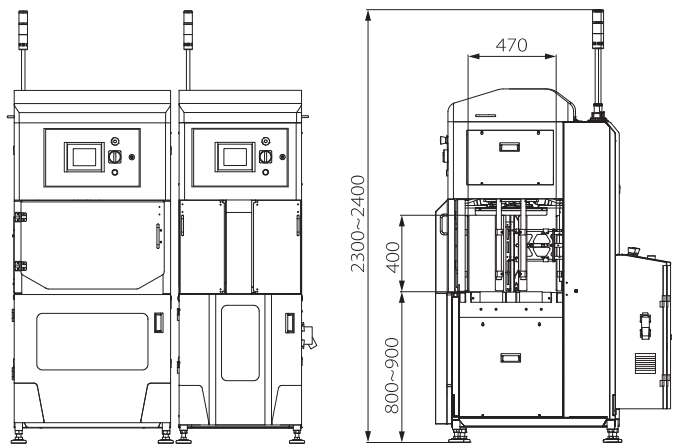
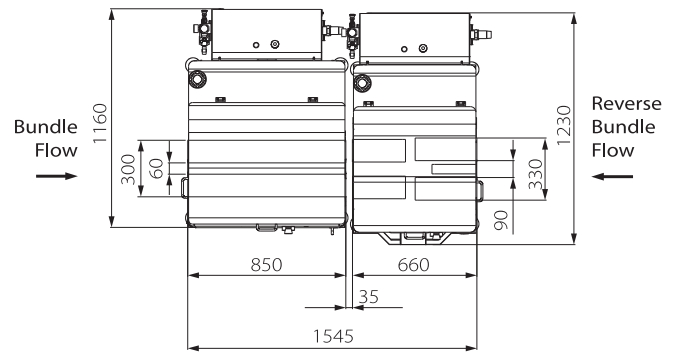

TP-702NIL

## Technical Data

<b>Capacity</b>	Up to 31 bundles/minute									
<b>Strap Width</b>	5 mm, 6 mm, or 9 mm									
<b>Tension Range</b>	1 - 32 kg									
<b>Bundle Size</b>	<table border="0"> <tr> <td><b>Width</b></td> <td>max 450 mm</td> <td>min 120 mm</td> </tr> <tr> <td><b>Length</b></td> <td>max 500 mm</td> <td>min 210 mm</td> </tr> <tr> <td><b>Height</b></td> <td>max 390 mm</td> <td>min 10 mm</td> </tr> </table>	<b>Width</b>	max 450 mm	min 120 mm	<b>Length</b>	max 500 mm	min 210 mm	<b>Height</b>	max 390 mm	min 10 mm
<b>Width</b>	max 450 mm	min 120 mm								
<b>Length</b>	max 500 mm	min 210 mm								
<b>Height</b>	max 390 mm	min 10 mm								
<b>Bundle Weight</b>	max 25 kg									
<b>Pneumatic Source &amp; Air Consumption</b>	6 bar 11.18 liter/cycle									
<b>Weight</b>	905 kg									
<b>Electrical Requirements</b>	220V, 380V, 400V, 415V 50/60Hz 3PH									

# Mercury TP-702NAD

## Cross Strapping System with Angle Diverter

TP-702NAD is a fully automatic strapping system with angle diverter for cross strapping requirement - meeting different plant layout requirements.



## Main Features

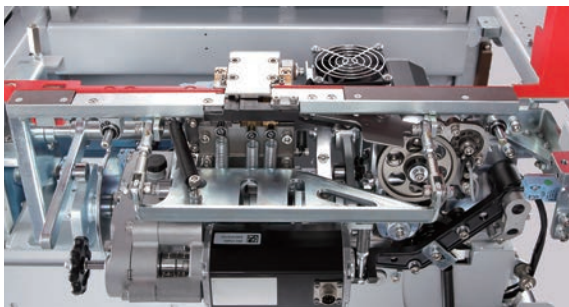

### Robust and Compact Strapping Head

Use the latest brushless DC motor direct drive technology to provide the highest level of accuracy and reliability. All motors are German-made. With compact design and fewer moving parts, it can greatly minimize the maintenance cost.

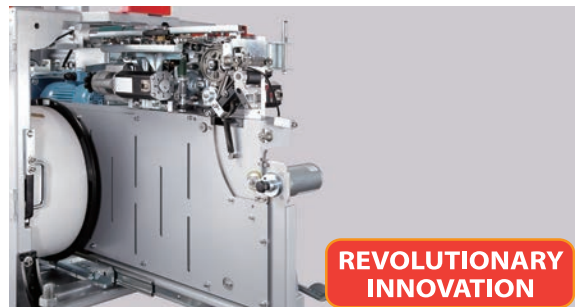

### Easy Access to Strapping Head (patents registered)

The strapping heads can be pulled out without moving the machine from production line. With this most user friendly design, operators can perform maintenance on-site directly to minimize downtime.

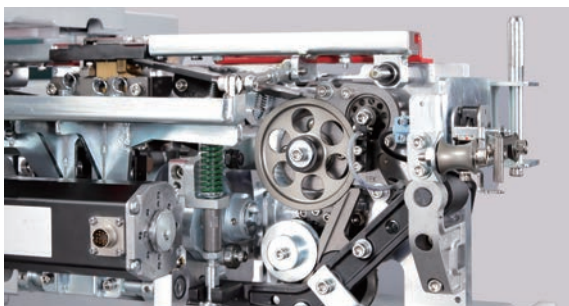

### Free Access to Strap Guides (patents registered)

Unlocking the guides enables free and quick access to strap guides without using any tools. The most maintenance friendly design.



### Siemens PLC Control and HMI

Provide easy adjustments, TEACH-IN programming, and troubleshooting guides.

## More Features

### Automatic Tension Control (patents registered)

The machine will automatically apply the most appropriate tension force to various bundle dimensions.

### Dual Pneumatic Press

Offer better bundle stability and containment.

### Up and Down Stream Interlock

With complete plug connection. Easily integrated into most production lines.

### Variable Conveyor Speed

Fully automatic operation with variable conveyor speed between 10 and 60 meters/minute.

### Strap End Ejector

Eject the end of strap from the inlet of strap feeding. Easy to clean the end of strap and get the machine ready for next coil of strap.

### Auto Strap Ejector

Loop-ejector clears unwanted strap automatically if the machine is accidentally activated without a package.

### Dispenser Release Switch

Friendly design makes it easier to pull the strap from the strap dispenser for waist-high auto strap feeding.

### Adjustable Table Height

The table height is adjustable to any height between 800 mm and 900 mm.

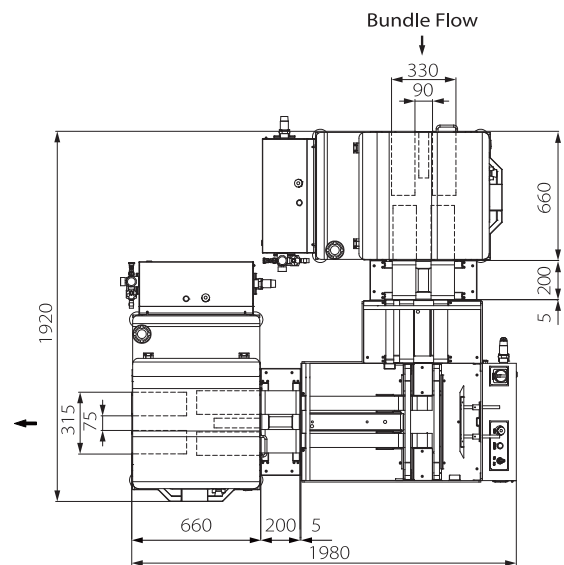
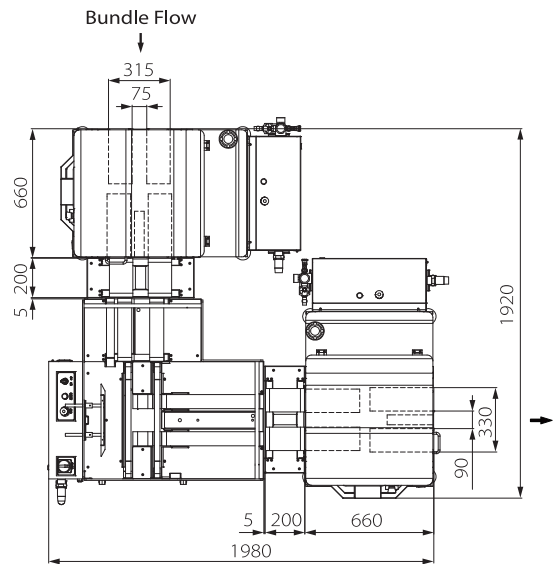

TP-702NAD

## Options

- **Energy saving transit with auto sleep mode**
- **Light tower with low strap sensor** (triple lamp)
- Additional soft press for convex bundle
- **Automatic side squaring**
- Low volume bundle bypass
- Movable casters (picture shown with this option)
- Lever switch for bundle with wrapping
- Safety guards (picture shown with this option)

## Technical Data

<b>Capacity</b>	Up to 25 bundles/minute		
<b>Strap Width</b>	5 mm, 6 mm, or 9 mm		
<b>Tension Range</b>	1 - 32 kg		
<b>Bundle Size</b>	<b>Width</b>	max 500 mm	min 210 mm
	<b>Length</b>	max 500 mm	min 210 mm
	<b>Height</b>	max 390 mm	min 10 mm
<b>Bundle Weight</b>	max 25 kg		
<b>Pneumatic Source &amp; Air Consumption</b>	6 bar		
	5.5 liter/cycle		
<b>Weight</b>	1,045 kg		
<b>Electrical Requirements</b>	220V, 380V, 400V, 415V 50/60Hz 3PH		

# Auxiliary Equipment for Print Media Industry

## N-AC

Accumulating Conveyor for Strapping Line Integration

N-AC is an accumulating conveyor designed for bundle buffering. It can be easily connected with upstream stacker and downstream strapper for bundle accumulating and transporting.



### Main Features

- Photo-eye control
- Siemens PLC control
- Adjustable table height (800 mm – 900 mm)
- Variable conveyor speed
- Upstream and downstream interlocks with complete plug connection

### Technical Data

<b>Conveyor Speed</b>	10 - 60 meters/minute
<b>Bundle Size</b>	<b>Width</b> max 450 mm min 100 mm <b>Length</b> max 450 mm min 120 mm <b>Height</b> max 400 mm min 5 mm
<b>Weight</b>	100 kg
<b>Electrical Requirements</b>	220V, 380V, 400V, 415V 50/60Hz 3PH

## N1-AD

Fully Automatic Multi-Angle Diverter

N1-AD Angle Diverter is specifically designed for bundle distribution. With its multiple infeed and transport direction, N1-AD is able to streamline the execution of your distribution system.



### Main Features

- Photo-eye control
- Siemens PLC control
- Multiple infeed and transport directions
- Adjustable table height (795 mm – 915 mm)
- Combined with strapping machines for cross strapping

### Technical Data

<b>Capacity</b>	Up to 25 bundles/minute
<b>Bundle Size</b>	<b>Width</b> max 500 mm min 180 mm <b>Length</b> max 500 mm min 180 mm <b>Height</b> max 380 mm min 10 mm
<b>Weight</b>	185 kg
<b>Electrical Requirements</b>	220V, 380V, 400V, 415V 50/60Hz 3PH



FULL STRAP SRL

Via delle industrie 11 - 13856 Vigliano Biellese (BI) - Italy

Tel. +39 015 3353310 - e-mail info@fullstrap.com

www.fullstrap.com