



Full Strap
Advanced Strapping Systems



SIDE-SEAL STRAPPING MACHINES



Transpak Side-Seal Strapping Machines

Mercury Series



TP-702Y/TP-702YA

- High value-added machine with high strapping speed to meet fast production line
- For 5 mm, 6 mm, 9 mm, or 12 mm PP strapping
- Robust and compact mechanical strapping head
- Latest German-made brushless DC motor direct drive technology
- Free access to strap guides (patents registered)
- Downward tension force
- Inner strap dispenser design
- Auto strap ejector
- Up and down stream interlock (TP-702YA)
- Capacity up to 60 cycles per minute for TP-702Y and up to 35 packages per minute for TP-702YA



TP-702YM/TP-702YAM

- High value-added machine with high strapping speed to meet fast production line
- Wash-down machine (water proof design)
- For 5 mm, 6 mm, 9 mm, or 12 mm PP strapping
- Robust and compact mechanical strapping head
- Latest German-made brushless DC motor direct drive technology
- Free access to strap guides (patents registered)
- Downward tension force
- Inner strap dispenser design
- Auto strap ejector
- Up and down stream interlock (TP-702 YAM)
- Capacity up to 60 cycles per minute for TP-702YM and up to 35 packages per minute for TP-702YAM



Tauris Series

Economy Machine



TP-601Y/TP-601YA

- Reliable and robust Tauris TP-601D lubrication free strapping head
- For 8 mm, 9 mm, or 12 mm PP strapping
- Auto strap feeding
- Electronic tension control
- Auto strap ejector
- Auto strap refeed
- Up and down stream interlock (TP-601YA)
- Capacity up to 29 cycles per minute for TP-601Y and up to 18 packages per minute for TP-601YA

TP-601YPT

- Reliable and robust strapping head
- **Friction weld sealing technology**
- For 9 mm, 12 mm, or 15.5 mm **PP and PET** strapping
- Siemens PLC
- Electronic tension control
- Auto strap ejector
- Auto strap refeed
- Up and down stream interlock with photo-eye control
- Capacity up to 11 cycles per minute

TP-201Y/TP-201YS

- Affordable choice for every budget
- TP-201Y painted steel frame version and TP-201YS stainless steel frame SUS 304 version
- Easy operation, simple maintenance
- For 6 mm - 15.5 mm PP strapping
- Mechanical tension control
- Suitable for low volume applications

Mercury TP-702Y / TP-702YA

Side-Seal Machine with Painted Steel Frame

TP-702Y and TP-702YA are high-speed side-seal strapping machines built with Transpak Mercury strapping head and brushless DC motor technology. They can be put into a wide range of applications, such as household appliances, furniture, tile industries, logistics, etc. Inheriting all the advantages from Mercury TP-702, they are ideal for high capacity and efficiency automated lines.

TP-702Y Automatic model



TP-702YA Fully-Auto model



Main Features

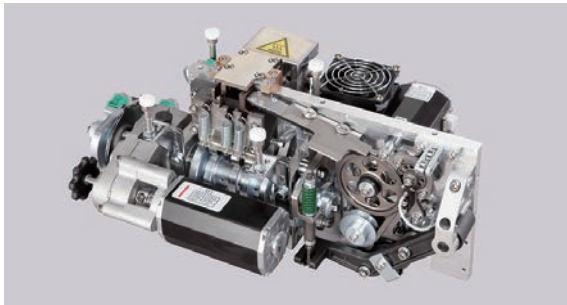

Robust and Compact Strapping Head

Use the latest brushless DC motor direct drive technology to provide the highest level of accuracy and reliability. All motors are German-made. Without belts, clutches, and pulleys, its compact design greatly minimizes the numbers of moving parts and maintenance cost.



Control Panel with LCD Display

The operating control panel is located on upper side of the machine for easy access. The LCD display shows the machine condition for easy operation and maintenance.



Free Access to Strap Guides (patents registered)

Unlocking the guides enables free and quick access to the strap guides without using any tools. The most maintenance friendly design.



Inner Strap Dispenser Design

The position of strap dispenser is inside the machine frame. It makes coil change in the most convenient and labor-saving way.

More Features

Downward Tension Force

Offer the most consistent tension to the package and help to hold package much firmly.

Auto Strap Ejector

Loop-eject clears unwanted strap automatically if the machine is accidentally activated without a package.

Strap End Ejector

Eject the end of strap from the inlet of strap feeding. Easy to clean the end of strap and get the machine ready for next coil of strap.

Adjustable Table Height

The table height is adjustable to any height between 445 mm and 645 mm.

Up and Down Stream Interlock (TP-702YA)

With complete plug connection. Easily integrated into most production lines.

Sensor Controlled Heater

The fast heating mechanism is sensor controlled assuring consistent and high sealing efficiency.

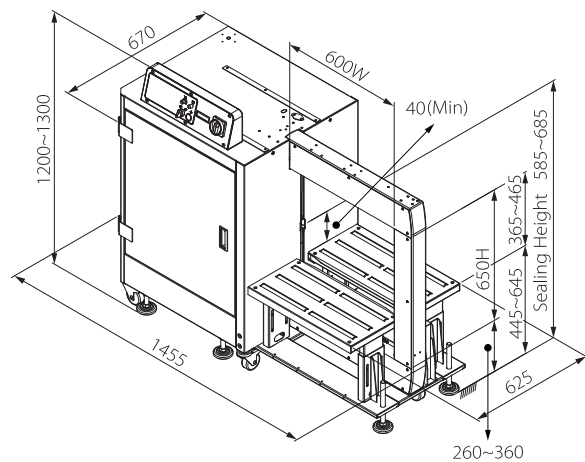

TP-702Y

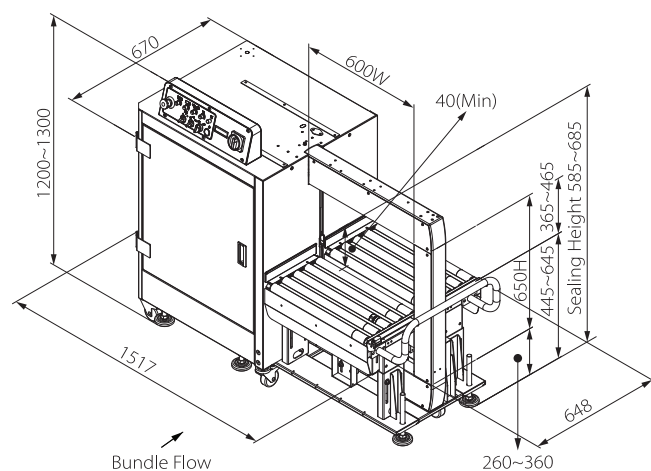

TP-702YA

Options

- Light tower with low strap sensor
- Small package
- Siemens PLC (for TP-702YA)
- Energy saving transit with auto sleep mode (for TP-702YA)
- End of cycle and strapping error signals (for TP-702Y)
- Without adjustable roller table (TP-702Y-XT)

• Side Pusher (for TP-702YA)

Push the package towards strapping head for better strapping performance.



• Dual Press Bar

Ideal to strap compressible materials or telescoped boxes.



Arch Sizes

| H \ W | 600 | 800 | 1000 | 1300 |
|-------|-----|-----|------|------|
| 650 | Ⓢ | N/A | N/A | |
| 850 | | | N/A | |
| 1050 | | | | |
| 1250 | | | | |
| 1650 | N/A | N/A | | N/A |
| 1850 | | N/A | | N/A |

Ⓢ Standard size: 600 mm (W) x 650 mm (H)

- N/A means not available
- More arch sizes are on request

Technical Data

| | |
|--------------------------------|--|
| Capacity | Up to 60 cycles/minute (TP-702Y) Up to 35 packages/minute (TP-702YA) |
| Strap Width | 5 mm, 6 mm, 9 mm, or 12 mm |
| Tension Range | 1 - 32 kg (for 5 mm, 6 mm, and 9 mm) 1 - 55 kg (for 12 mm) |
| Weight | 294 kg (TP-702Y) 340 kg (TP-702YA) |
| Electrical Requirements | 110V, 220V, 230V, 240V 50/60Hz 1PH 220V, 380V, 400V, 415V 50/60Hz 3PH |

Mercury TP-702YM / TP-702YAM

Side-Seal Wash-Down Machine

TP-702YM and TP-702YAM are wash-down side-seal strapping machines built with Transpak Mercury strapping head and brushless DC motor technology. With stainless steel cabinet (SUS 304) and rust resistant or corrosion retardant components, TP-702YM and TP-702YAM provide maximum protections for the applications in the harsh working environment like seafood, meat, and poultry processing industries.

TP-702YM Automatic model



TP-702YAM Fully-Auto model



Main Features

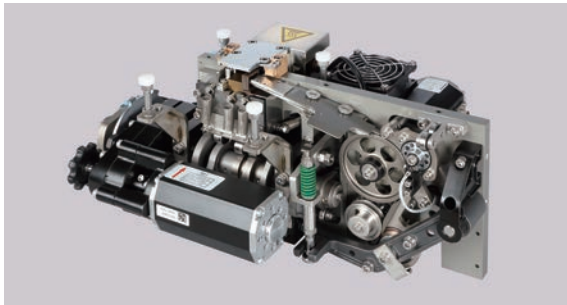

Robust and Compact Strapping Head

Use the latest brushless DC motor direct drive technology to provide the highest level of accuracy and reliability. All motors are German-made. Without belts, clutches, and pulleys, its compact design greatly minimizes the numbers of moving parts and maintenance cost.

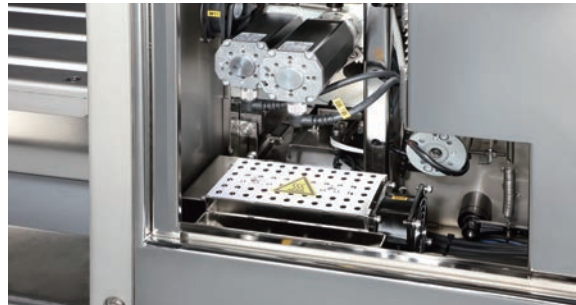

Water Proof Design

Internal heating device assists to prevent accumulating humidity inside. Special protection for electric control unit with IP 54 rated ensures highest safety. Provide most strict protection from water and wash down spray.



Free Access to Strap Guides (patents registered)

Unlocking the guides enables free and quick access to the strap guides without using any tools. The most maintenance friendly design.



Downward Tension Force

Offer the most consistent tension to the package and help to hold package much firmly. It also offers the best packaging solution for food industry with styrofoam box.

More Features

Electronic Tension Control

The operating control panel with LCD display is located on upper side of the machine for easy access. Strap tension can be adjusted accurately by a simple turn of the dial.

Inner Strap Dispenser Design

The position of strap dispenser is inside the machine frame. It makes coil change in the most convenient and labor-saving way. This design also protects the strap dispenser from moisture.

Auto Strap Ejector

Loop-eject clears unwanted strap automatically if the machine is accidentally activated without a package.

Adjustable Table Height

The table height is adjustable to any height between 445 mm and 645 mm.

Up and Down Stream Interlock (TP-702YAM)

With complete plug connection. Easily integrated into most production lines.

Low Voltage

All DC motors and heater are “stepped down” to 24V to increase the safety level of the machine.

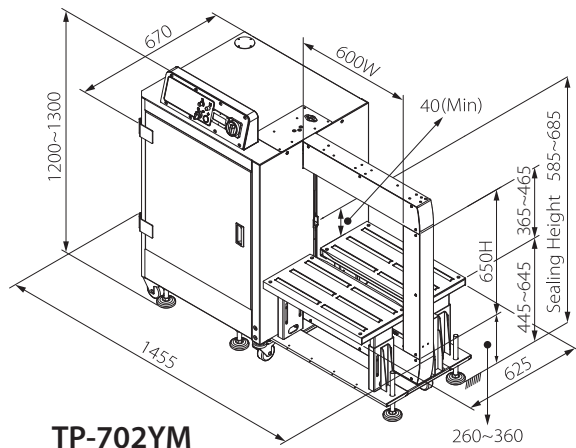

TP-702YM

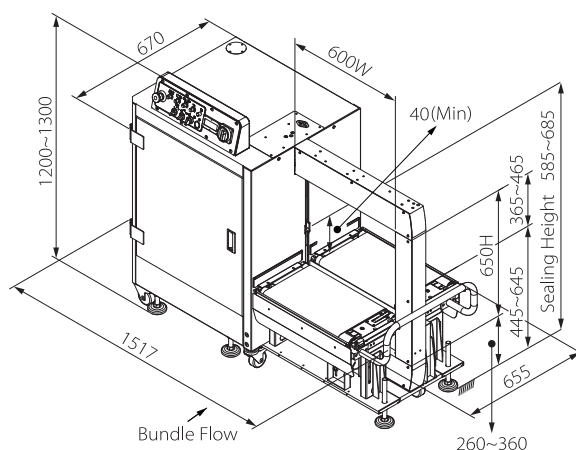

TP-702YAM

Options

- Light tower with low strap sensor
- Small package
- Siemens PLC (for TP-702YAM)
- Energy saving transit with auto sleep mode (for TP-702YAM)
- End of cycle and strapping error signals (for TP-702YM)
- Without adjustable roller table (TP-702YM-XT)
- **Side Pusher** (for TP-702YAM)

Push the package towards strapping head for better strapping performance.



- **Dual Press Bar**
Ideal to strap compressible materials or telescoped boxes.



Arch Sizes

| H \ W | 600 | 800 |
|-------|-----|-----|
| 650 | Ⓢ | N/A |
| 850 | | |

- Ⓢ Standard size : 600 mm (W) x 650 mm (H)
- N/A means not available

Technical Data

| | |
|--------------------------------|---|
| Capacity | Up to 60 cycles/minute (TP-702YM) Up to 35 packages/minute (TP-702YAM) |
| Strap Width | 5 mm, 6 mm, 9 mm, or 12 mm |
| Tension Range | 1 - 32 kg (for 5 mm, 6 mm, and 9 mm) 1 - 55 kg (for 12 mm) |
| Weight | 281 kg (TP-702YM) 327 kg (TP-702YAM) |
| Electrical Requirements | 110V, 220V, 230V, 240V 50/60Hz 1PH |

Tauris TP-601Y / TP-601YA

Side-Seal Machine with Painted Steel Frame

TP-601Y and TP-601YA are using the same reliable and robust strapping head as Tauris TP-601D. They are ideal for strapping large or heavy products and household appliances. With side mounted strapping head, it is also applicable in dusty working environment such as sawmill plants, brick, and tile industries. Wide range of arch sizes is available to meet various applications.

TP-601Y Automatic model



TP-601YA Fully-Auto model



Main Features

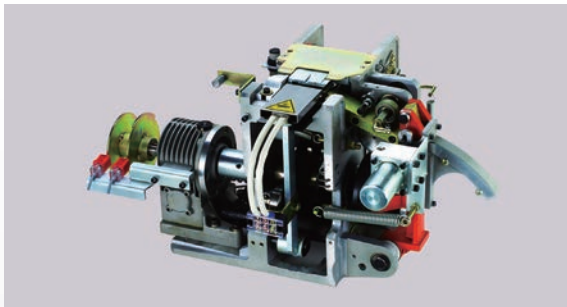

Reliable and Robust Strapping Head

Robust mechanism design and high engineering standard ensure excellent durability of the machine. Use two proximity switches to replace conventional limit switches.



Auto Strap Feeding

Simply insert the strap into the feeding rollers and then push the "reset" button. The machine will automatically feed the strap without the need to access to the inside of the machine.



Auto Strap Ejector

Loop-eject clears unwanted strap automatically if the machine is accidentally activated without a package. Eliminate downtime.



Electronic Tension Control

Strap tension can be adjusted accurately by a simple turn of the dial on the control panel.

More Features

Short Feed Sensor

The sensor detects whether the strap is at sealing position. If not, the strapping cycle cannot be activated.

Auto Strap Refeed

The machine will automatically refeed the strap if a mis-feed occurs.

Strap End Ejector

Eject the end of strap automatically. Easy to clean the end of strap and get the machine ready for next coil of strap.

Lubrication Free Strapping Head

No lubrication is required for the strapping head. Therefore, it minimizes the maintenance and saves the cost. Easy maintenance.

Up and Down Stream Interlock (TP-601YA)

With complete plug connection. Easily integrated into most production lines.

Adjustable Weld Cooling Time

Weld cooling time is adjustable from 0 to 2 seconds. It ensures the high sealing efficiency when the machine is set at high tension.

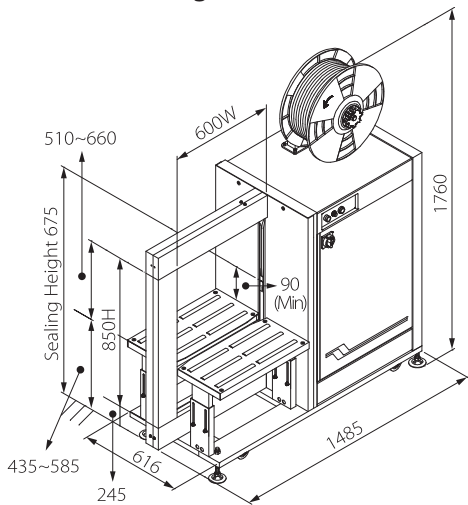

TP-601Y

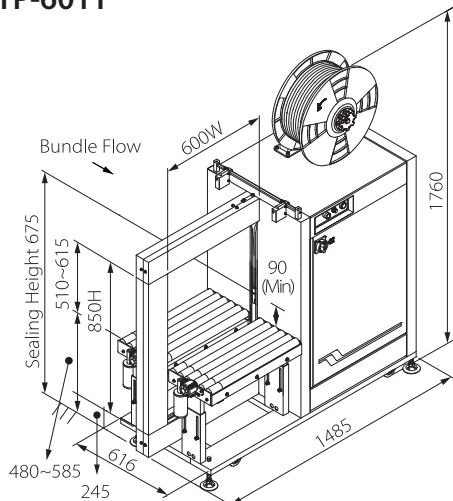

TP-601YA

Options

- Emergency stop switch
- Foot pedal switch (for TP-601Y)
- Siemens PLC (for TP-601YA)
- **PU casters**
Two free and two with brake. Smooth and silent movement.
- Uplifted support
- Without adjustable roller table (TP-601Y-XT, TP-601YA-XT)

Arch Sizes

| W | 400 | 600 | 800 | 1000 | 1200 |
|------|-----|-----|-----|------|------|
| 650 | | | N/A | N/A | N/A |
| 850 | | Ⓢ | | | |
| 1050 | | | | | |
| 1250 | | | | | |
| 1450 | | | | | |
| 1650 | | | | | |
| 1850 | | | | | N/A |

Ⓢ Standard size : 600 mm (W) x 850 mm (H)

• N/A means not available

Technical Data

| | |
|--------------------------------|--|
| Capacity | Up to 29 cycles/minute (TP-601Y) Up to 18 packages/minute (TP-601YA) |
| Strap Width | 8 mm, 9 mm, or 12 mm |
| Tension Range | 7 - 45 kg (TP-601Y) 7 - 70 kg (TP-601YA) * up to 70 kg on request for TP-601Y |
| Table Height | 435 - 585 mm (TP-601Y) 480 - 585 mm (TP-601YA) |
| Conveyor Speed | 10 - 40 meters/minute (TP-601YA) |
| Weight | 300 kg (TP-601Y) 333 kg (TP-601YA) |
| Electrical Requirements | 110V, 220V, 230V, 240V 50/60Hz 1PH (TP-601Y) 220V, 380V, 400V, 415V 50/60Hz 3PH (TP-601Y, TP-601YA) |

Tauris TP-601YPT

Side-Seal Machine for PP and PET strapping

TP-601YPT is an automatic side-seal strapping machine for **PP and PET** strapping (9 mm, 12 mm, or 15.5 mm). With the extra-large arch sizes available, TP-601YPT is ideal for applications on large and/or heavy products, household appliances (like refrigerator, television, or washing machine), and various palletized products. It can be integrated with most production lines.

TP-601YPT

PET PP

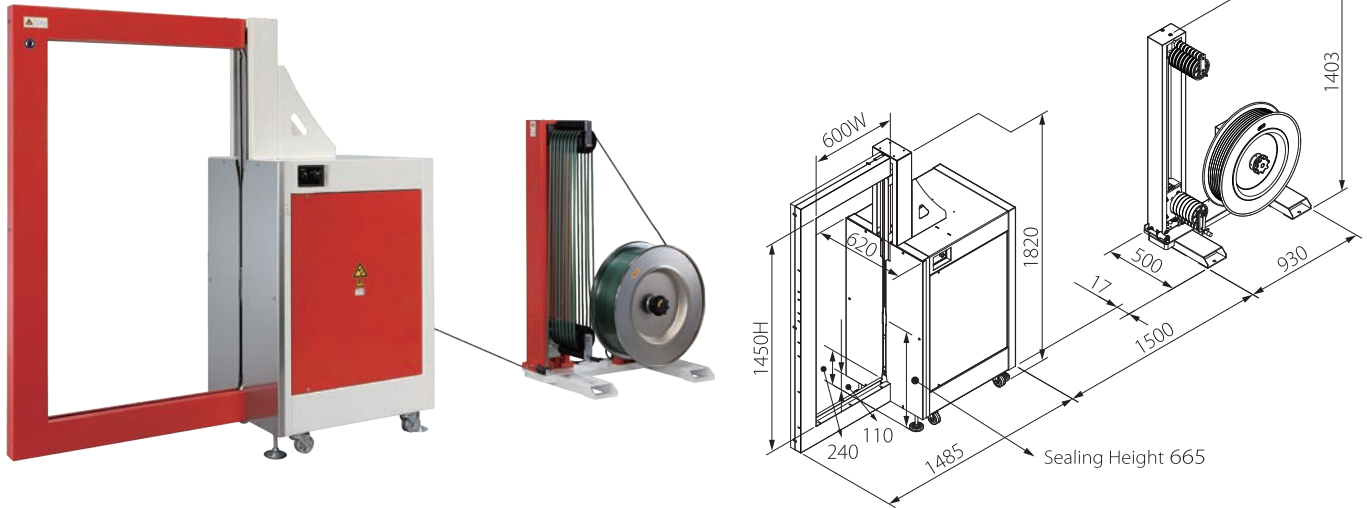

Main Features

Friction Weld Sealing Technology

The advanced friction weld sealing technology guarantees reliable joint and high sealing efficiency for both **PP and PET strapping**. No fumes and odours.

Siemens PLC

Siemens PLC is a state-of-the-art controller. It is programmable and can be expanded flexibly to meet various application requirements.

Electronic Tension Control

Strap tension can be adjusted accurately by a simple turn of the dial. Tension force is up to 1500 N (150 kg).

Auto Strap Refeed

The machine will automatically refeed the strap if a mis-feed occurs. Eliminate downtime.

Options

- Up and down stream interlock with photo-eye control
- Emergency stop switch
- Foot pedal switch
- Strap dispenser 90-degree turn
- PU casters (2 free and 2 with brake)
- Uplifted support
- With adjustable free roller table (TP-601YPT-T)

Arch Sizes

| H \ W | 600 | 800 | 1000 | 1200 | 1400 |
|-------|-----|-----|------|------|------|
| 850 | | | | | |
| 1050 | | | | | |
| 1250 | | | | | |
| 1450 | Ⓢ | | | | |
| 1650 | | | | | |
| 1850 | | | | | |
| 2050 | | | | | |
| 2250 | | | | | |
| 2450 | | | | | |

Ⓢ Standard size: 600 mm (W) x 1450 mm (H)

Technical Data

| | |
|--------------------------------|------------------------------------|
| Capacity | Up to 11 cycles/minute (60Hz) |
| Strap Width | 9 mm, 12 mm, or 15.5 mm |
| Tension Range | 20 - 150 kg |
| Strap Core Size | 406 mm (200/280 mm Optional) |
| Weight | 355 kg |
| Electrical Requirements | 220V, 380V, 400V, 415V 50/60Hz 3PH |

Economy Machine TP-201Y / TP-201YS

Affordable for every budget

TP-201Y and TP-201YS are semi-auto side-seal strapping machines. They are using the same strapping head as TP-202 Mr. Reliable which is widely recognized on the market for more than 30 years. They can be used in a wide range of applications for dirty, moist, or harsh working environment, such as sawmill plants, brick & tile industries, poultry processing industries, etc. TP-201Y and TP-201YS offer the most economy solution.

TP-201Y Painted steel frame

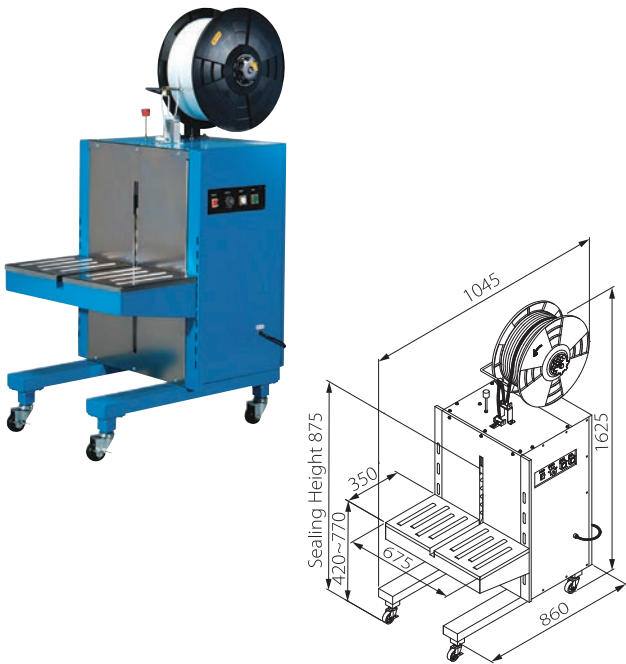

TP-201YS Stainless steel frame SUS 304

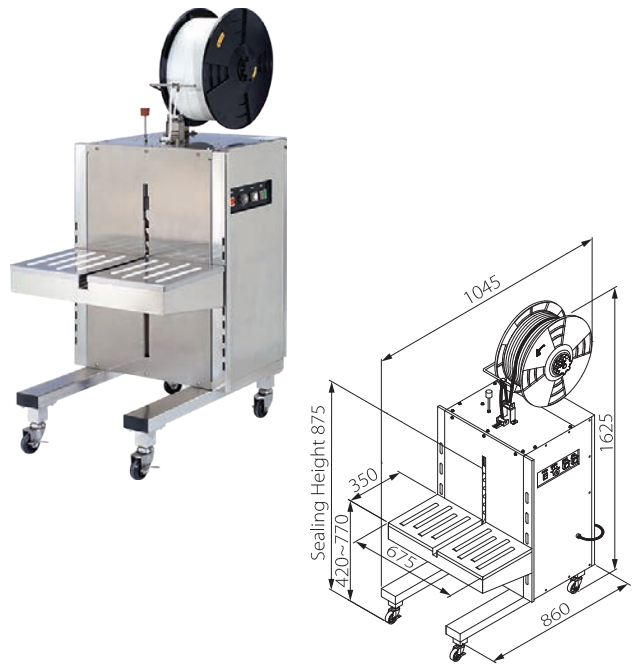

Main Features

- Offer high reliability and performance
- Suitable for low volume applications
- Easy operation, simple maintenance
- Mechanical tension control
- Reliable P.C. Board control
- Energy efficient - motor only runs as needed
- Rigid castors with brake
- Proven quality
- Adjustable table height between 420 mm and 770 mm

Options

- Adjustable cooling time (0-2 sec.)
- Selected parts in stainless steel (for TP-201YS)

Technical Data

| | |
|--------------------------------|------------------------------------|
| Strap Width | 6 mm - 15.5 mm |
| Tension Range | 15 - 45 kg |
| Weight | 125 kg |
| Electrical Requirements | 110V, 220V, 230V, 240V 50/60Hz 1PH |

ALWAYS MORE THAN YOU EXPECT

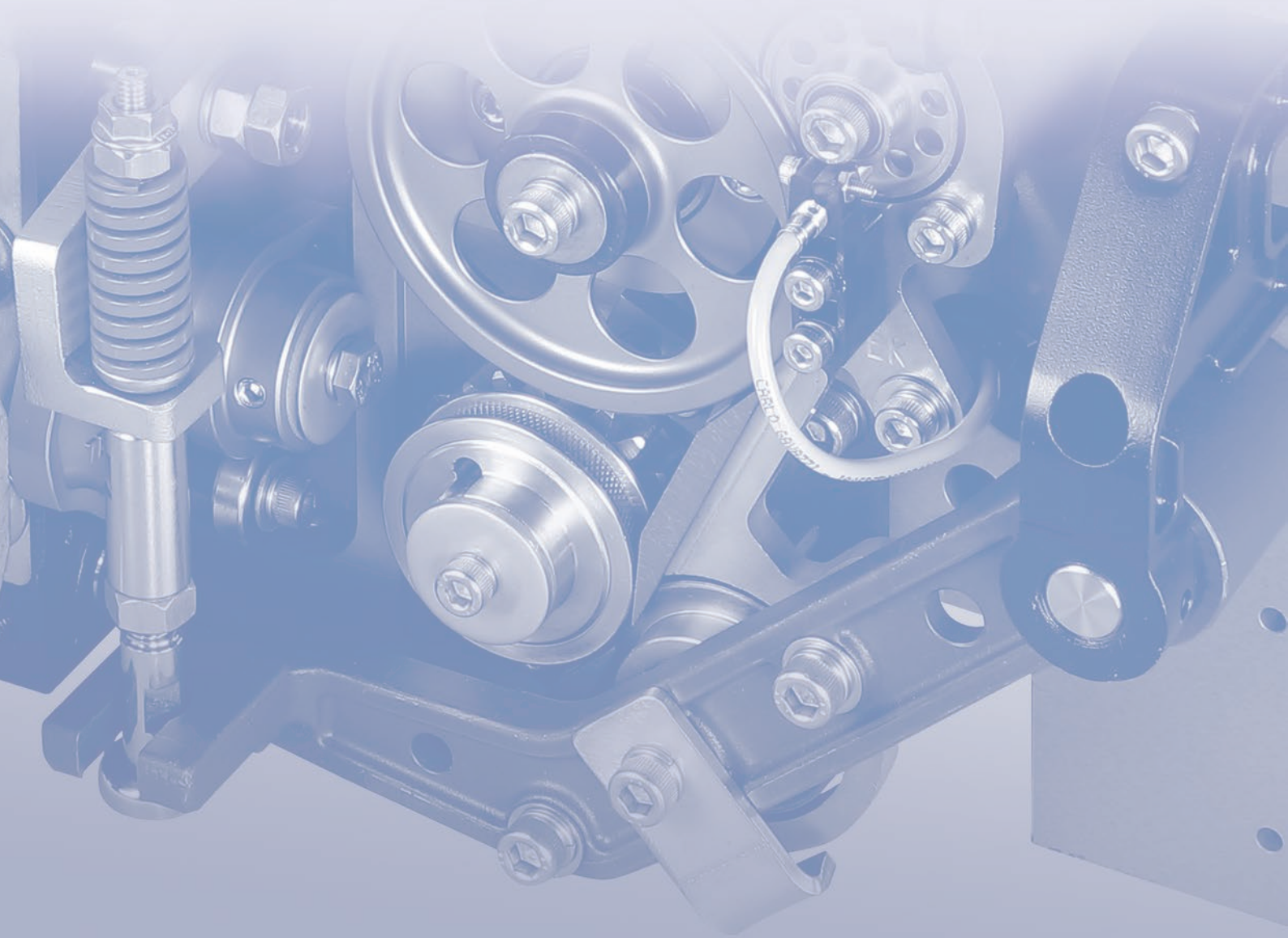

FULL STRAP SRL

Via delle industrie 11 - 13856 Vigliano Biellese (BI) - Italy

Tel. +39 015 3353310 - e-mail info@fullstrap.com

www.fullstrap.com