

Genesis Verti TP-502MV

Semi-Automatic Vertical Pallet Strapping Machine

TP-502MV inherits all of the advantages from Genesis TP-502, such as compact strapping head, direct drive technology with German-made DC motors, and electronic tension control. It eliminates the use of manual tools and dispensers, and can be moved easily beside the load you want to strap without moving the pallet. TP-502MV provides an ergonomic and cost-effective solution for low volume vertical pallet strapping applications.

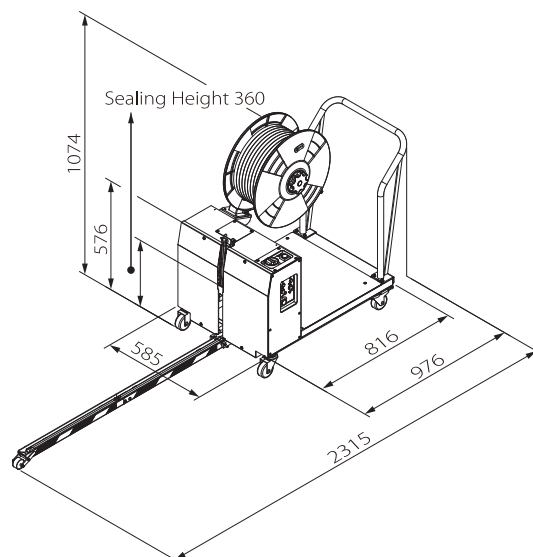

Main Features

Compact Mechanical Strapping Head

With 30% less moving parts than conventional machines substantially reduces maintenance issues. There are no belts, chains, or pulleys. Extremely low noise sealing head.

Electronic Tension Control

Strap tension can be adjusted accurately by a simple turn of the dial on the control panel. Tension force is up to 700 N (70 kg).

Jog Switch

Using the "Jog switch" to adjust the machine to exactly the correct position for maintenance.

Adjustable Weld-Cooling Time

The weld cooling time can be increased to ensure high joint efficiency under high tension.

Mobility

With light weight and compact size, it is easy to move the machine beside the pallet you want to strap.

Various Applications

Suitable for corrugated cardboards, concrete blocks, and pallet loaded with cardboard boxes containing any type of products.

Option

- Battery power supply (TP-502MVB)

Technical Data

Strap Type	PP strapping
Strap Width	9 mm, 12 mm, or 15.5 mm
Tension Range	8 kg – 70 kg
Minimum Package Height	380 mm (Incl. pallet)
Length of the Sword	1250 mm
Weight	93 kg
Electrical Requirements	110V, 220V, 230V, 240V 50/60Hz 1PH

Genesis Hori TP-502MH

Semi-Automatic Horizontal Pallet Strapping Machine

TP-502MH inherits all of the advantages from Genesis TP-502, such as compact strapping head, direct drive technology with German-made DC motors, and electronic tension control. It can be positioned easily beside the load you want to strap without moving the pallet. TP-502MH provides a quick, ergonomic, and economical solution for low volume horizontal pallet strapping applications.

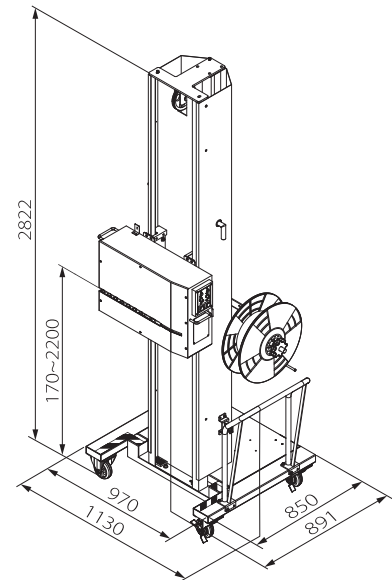

Main Features

Compact Mechanical Strapping Head

With 30% less moving parts than conventional machines substantially reduces maintenance issues. There are no belts, chains, or pulleys. Extremely low noise sealing head.

Electronic Tension Control

Strap tension can be adjusted accurately by a simple turn of the dial on the control panel. Tension force is up to 700 N (70 kg).

Jog Switch

Using the "Jog switch" to adjust the machine to exactly the correct position for maintenance.

Adjustable Weld-Cooling Time

The weld cooling time can be increased to ensure high joint efficiency under high tension.

Two Moving Direction

With simple adjustment, the machine can be moved either forward or sideward to approach the pallet.

Various Applications

Suitable for fruit & vegetable boxes, concrete blocks, and pallet loaded with cardboard boxes containing any type of products.

Options

- Edge protector holder
- Handle on the rear for back/forth movement
- Battery power supply (TP-502MHB)

Technical Data

Strap Type	PP strapping
Strap Width	9 mm, 12 mm, or 15.5 mm
Tension Range	8 kg – 70 kg
Strapping Height	min 170 mm max 2200 mm
Minimum Package Height	200 mm (Incl.pallet)
Weight	292 kg
Electrical Requirements	110V, 220V, 230V, 240V 50/60Hz 1PH