

MAGIC II TP-602MV

Semi Automatic Vertical Pallet Strapping Machine with Retractable Sword

Magic II TP-602MV is a portable semi-auto pallet strapping machine for vertical strapping applications. It works with both PP and PET strapping (9 mm, 12 mm, or 15.5 mm) and offers tension force up to 150 kg. It can be conveniently positioned next to the pallet, without having to move the load. The retractable sword that feeds the strap through pallet void not only saves time and effort in operation, but also space. Its high mobility and easy operation make it the most efficient solution for low to moderate pallet strapping needs.

Max. Tension
Up to 1500 N



Main Features

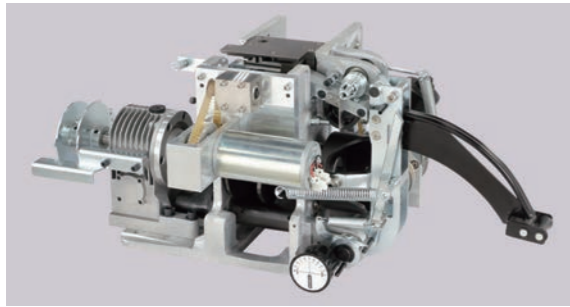

Robust and Lubrication Free Strapping Head

Applying robust mechanism design and high engineering standard with the latest German-made DC motor technology, it provides the highest level of reliability and durability. Requiring no lubrication for strapping head, it greatly simplifies the maintenance routine and minimizes the maintenance cost.



Retractable Sword

Motorized retractable sword feeds the straps through pallet void and automatically retracts during the strapping cycle. This design is space-saving, and it protects the sword from damage.

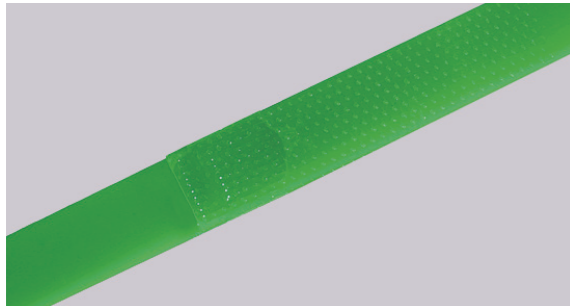

Friction Weld Sealing Technology

The advanced **friction weld sealing** technology guarantees reliable joint and high seal efficiency for both PP and PET strapping. No fumes and odours. Ready to use once turned on.



User-friendly Control Panel

The user-friendly operating control panel is located on upper side of the machine for easy access.

More Features

High Tension

Tension force is up to 1500 N (150 kg) - meeting the market demand for higher tension request for pallet strapping.

Low Sealing Height

Sealing height is only 485 mm from the floor so even lower pallets can be strapped.

Adjustable Weld-Cooling Time

The weld cooling time can be adjusted to ensure high joint efficiency under high tension.

Error Message Indicator

Provides diagnostic error code for easy troubleshooting. It helps with maintenance and minimizes the down time.

Good Mobility

Large casters provide good mobility. It is easy to move the machine beside the pallet you want to strap.

Manual Feeding

With the **auxiliary feeding switch** on the operating control panel, it's allowed to manually feed more strap for larger pallet loads.

Two Operation Modes

Automatic and semi-auto modes to meet various strapping requirements. Single operator can do the job even if applying edge protector is needed.

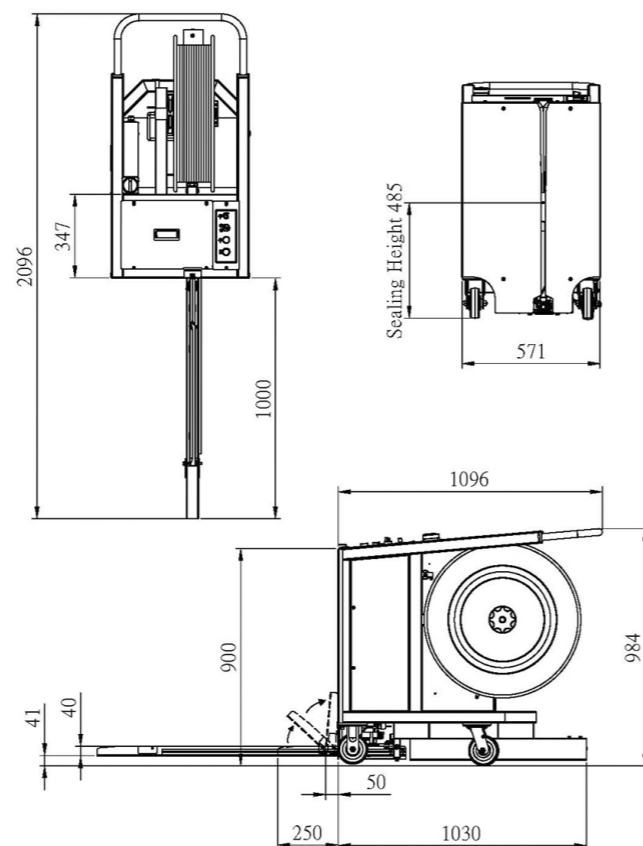

TP-602MV



Technical Data

Strap Type	PP and PET strapping
Strap Width	9 mm, 12 mm, or 15.5 mm
Tension Range	70 - 1,500 N
Sealing Height	485 mm
Length of the Sword	1,000 mm
Minimum Package Height	560 mm (pallet included)
Strap Core Size	406 mm (Option: 200 mm/230 mm/280 mm)
Electrical Requirements	110V 60Hz 1PH 220V, 230V, 240V 50/60Hz 1PH

**Offer the Maximum Value
with the Minimum Cost.**

Always More than You Expect.

